

# The Sterling Digibinder®

## Operator's Training Manual

Issue 1 October 1, 2013



This manual is for both versions of the Sterling Digibinder and Sterling Digibinder Plus.

The Digibinder Plus sits on its own stand/cabinet which houses both the air compressor and the dust extractor. To turn on the Dust Extractor, locate the toggle switch on the front of the machine.

**You can bypass the safety hood's sensor by using the supplied key(s) located near the Dust Extractor switch.**

## Table of Contents

GETTING STARTED .....	3
POWERING UP .....	7
CONTROL PANEL.....	7
SETTING UP THE DIGIBINDER .....	8
SETTING THE CLAMP LIMITER .....	9
ALIGNING THE COVER STOCK .....	10
BOOK THICKNESS WHEEL & NIPPER ADJUSTMENT KNOB.....	10
SIDE GLUE ADJUSTMENT .....	11
ADJUSTING THE STRENGTH OF THE BIND .....	12
GETTING INTO PRODUCTION .....	13
MAKING PADS .....	13
DRAINING THE GLUE.....	13
DAILY MAINTENANCE .....	14
WEEKLY MAINTENANCE .....	14
TROUBLESHOOTING .....	15
UNEVEN OR INCONSISTENT SIDE GLUE.....	15
ADJUSTING SIDE GLUE BETWEEN HEAD AND FOOT OF BOOK.....	15
ADJUSTING SIDE GLUE ON OPERATOR AND NON-OPERATOR SIDES OF THE BOOK .....	16
PAGES NOT BINDING WELL.....	16
ROUGHING BLADE AND NOTCHING PINS ADJUSTMENT.....	17
UNEVEN CORNERS ON THE BOOK SPINE.....	18
LEVELING THE NIPPER TABLE.....	18
MACHINE DOES NOT CYCLE .....	19
MACHINE BEEPS TWICE IN RAPID SUCCESSION AND DOES NOT CYCLE.....	19
CLAMP IS STUCK / ERROR MESSAGE.....	19

## GETTING STARTED

Congratulations on your purchase of THE STERLING DIGIBINDER or DIGIBINDER PLUS. This machine will allow you to perfect bind any book up to 2 ¼" or 55mm thick.

**For the Tabletop version:** Before removing the machine from the shipping crate, have a table ready that will support 330 LBS (150 kg). Uncrate the machine and inspect it for any damage that may have occurred during transport. Place the Sterling Digibinder on the table. Use of a lift truck is recommended. Be careful to avoid injury.

Remove the compressor from the box and stand it on a solid surface. **Do not place the compressor in an enclosed area such as a cabinet unless it is well ventilated.** The air filter should already be installed on the compressor but if not, locate it within the compressor box and install it onto the fitting. (FIG #1) Do not over tighten.



**Figure 1**

Plug the Digibinder's power cord and the Air Compressor's power cord into the back of the Digibinder. (FIG #2)



**Figure 2**

Install the exhaust fan, Start by attaching the connectors. Press the connectors back into the cavity along with any slack of the cord and screw in the exhaust fan. Flip the exhaust box power switch on. (FIG #3)



**Figure 3**

Plug the Digibinder's blue air tube and the supplied air gun into the "Y" air splitter then plug the air splitter's tube into the compressor. (FIG #4)

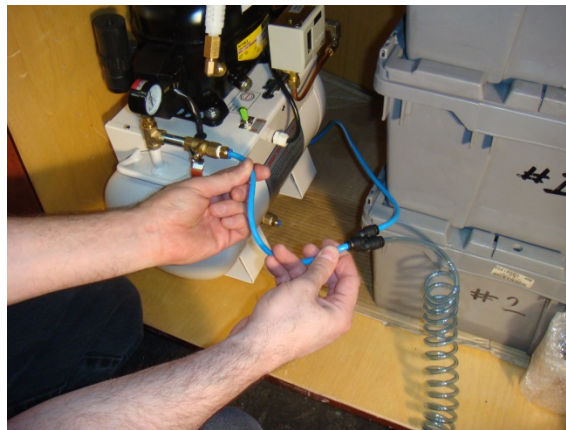

**Figure 4**

Open the valve on the compressor's pressure gauge (FIG #5) and flip the toggle switch to the on position. Make sure the bleed valve at the bottom of the compressor is closed (not shown). (FIG #5 - Arrow)

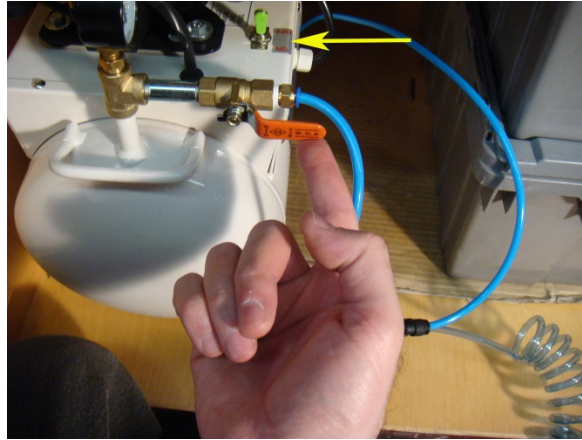

**Figure 5**

Attach the Tall Book Guide on top of the clamp. (FIG #6)

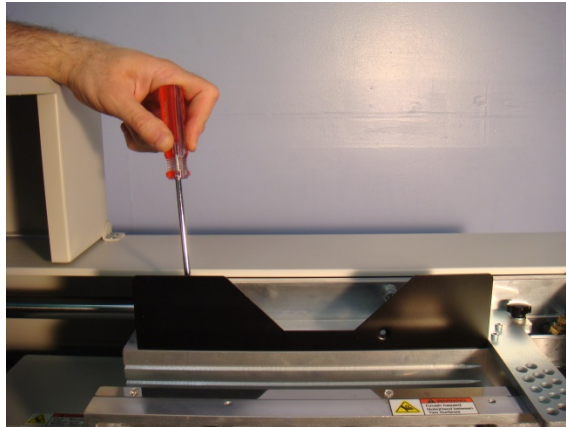

**Figure 6**

Install The Front Book Support. (FIG #7)



**Figure 7**

Install the Rear Table Cover Support behind the Nipper Table. (FIG #8)

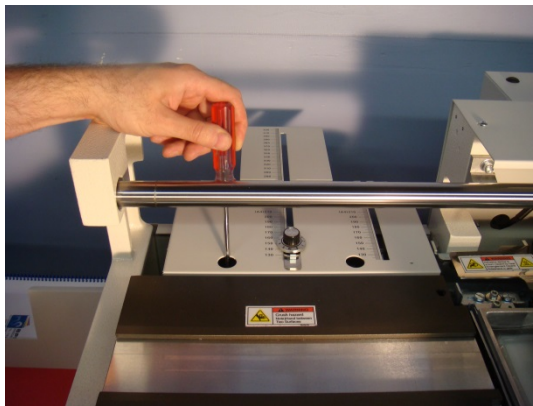

**Figure 8**

Screw in the Nipper Adjustment Knob on the front of the Nipper Table. (FIG #9)



**Figure 9**

For the DIGIBINDER PLUS: Use a fork lift to lift the machine off the skid. Keep the machine steady, it is top heavy. Make sure all four wheels have the stops in the up position before placing it on flat level ground. Once the machine has been moved to its final position, lower the stops to prevent the machine from rolling. To install the accessories, follow the previous set of instructions for the Table Top Digibinder. Some parts may already be installed.

## POWERING UP

Have your electrician check that your incoming power is 220 volts, single phase, 15 amps. Have your electrician attach a plug onto the end of the Digibinder's Power Cord that matches your socket.

The Power Switch is located on the right side of the Digibinder. Turn on the Digibinder and check that the screen lights up along with a red LED indicating the gluepot heater is on and working. Make sure the Emergency Stop button is in the up position. If not, give it a gentle twist clockwise to release it.

## CONTROL PANEL

(FIG #10)

The keypad controls the functions of the Digibinder for operation, set up or troubleshooting. The following is a list of the control buttons and switches. See the figure below.

1. **START:** This will cycle the Digibinder fully through the binding process. This will not function unless there is a book in the clamp and cover stock on the nipper table.
2. **CLAMP:** Opens and closes the clamp. Use this feature for setting the clamp to the thickness of your book by utilizing the clamp limiter bar (more on that later).
3. **Green LED:** The machine will not cycle until the glue has fully melted and this LED is lit.
4. **UP:** Raises the glue temperature or increases the nipper's finish time.
5. **DOWN:** Lowers the glue temperature or decreases the nipper's finish time.
6. **Red LED:** Indicates that the glue heater is on.
7. **X:** Clears the functions of the glue rollers, drops and opens the nipper table (if in the up and closed position), resets the batch count and toggles the padding feature on or off.
8. **O:** Stand by. Lowers the glue temperature to 130 and prevents any function of the Digibinder.  
**\*\*Also cycles the roughing motor if the Digibinder is in the SET UP Mode.**
9. **NIPPER CLOSE:** Closes the nipper table. Press **X** to open.
10. **NIPPER UP:** Raises the nipper table. Press **X** to drop.

11. **LEFT:** Moves the clamp to the left.
12. **RIGHT:** Moves the clamp to the right.
13. **CYCLE GLUE ROLLERS:** Use when adding glue. Glue should be approximately  $\frac{3}{4}$ " below the top of the gluepot.
14. **SET:** Pressing the UP or DOWN arrows on the 1<sup>st</sup> screen changes the glue pot temperature. The counter on this screen cannot be reset.  
Press SET once for the Padding Mode screen. Press **X** to toggle padding on or off.  
Press SET again For the Finish Time. Use the UP or DOWN arrows to set the Nipper Table dwell time. If padding is on, each increment would add 10 seconds. 15 would equal 150 seconds. If padding is off, 15 would equal 4 seconds.  
Press SET a third time to get to the batch counter. This counter can be reset using the **X** button.  
Press SET once more to return to the main screen.
15. **POWER SWITCH:** Located on the right side of the machine.
16. **TOGGLE SWITCH:** Turns the roughing motor on or off. The toggle switch is located below the Main Power Switch. Leave up for perfect binding or down for making pads.



Figure 10

### SETTING UP THE DIGIBINDER

Turn on the Digibinder to warm up the glue pot. The machine will not cycle until the glue has thoroughly melted. This should not take longer than 45 minutes. During this time, the green LED will remain off and you cannot change the settings from the control panel. The temperature will rise above the set value then gradually lower to the set temperature. When the machine is ready, the glue rollers will cycle, the machine will give 3 audible beeps and the green LED will light indicating it is now ready for use. At this time, you may adjust the temperature if needed. We recommend 160 degrees centigrade. The machine will not cycle if the green LED is off (FIG #10, item 3), without a book in the clamp (FIG #11) or cover stock on the nipper table (FIG #12).



Figure 11

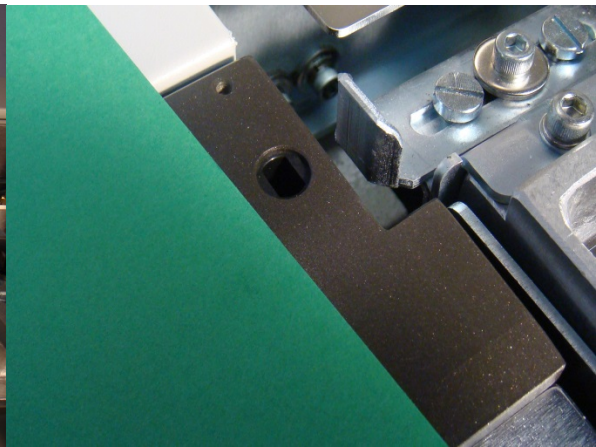

Figure 12

Put a cover in position on the nipper table placing it square to the right stops with the rear edge tucked under the top stop guide. Loosen the top stop guide and adjust accordingly, depending on the size of the book. The rear of the book's spine will line up with the scored line in the nipper table. (FIG #13)

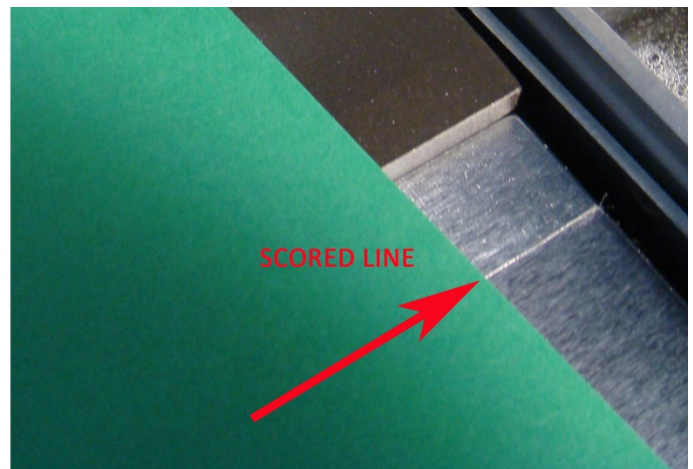
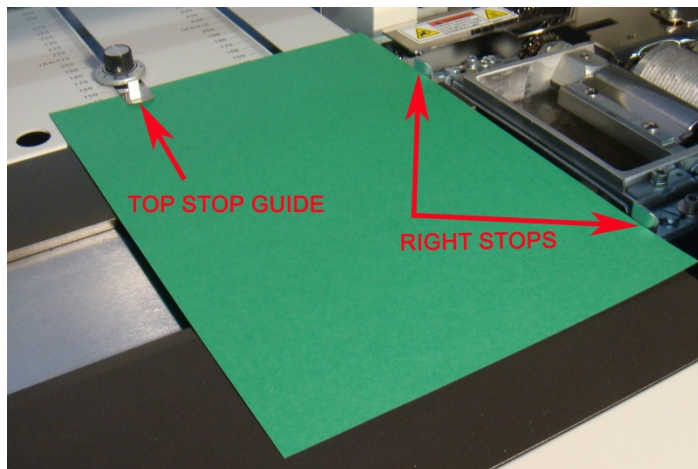

Figure 13

### SETTING THE CLAMP LIMITER

Place the book block in the open clamp and jog it to the right, then press the CLAMP button. After the clamp closes, move the Limiter Bar's Pin into the second closest hole to the front, outside of the clamp. This will limit how wide the clamp opens so placing books of the same thickness will be easier and quicker. Press CLAMP again to open the clamp. Check that the clamp's opening is approximately ¼" wider than the book's thickness. This will ensure the clamp will not drag the book back after it has been bound. (FIG #14)



Figure 14

It is not necessary to continue to use the CLAMP button once the clamp opening is set. Simply place the book inside the clamp and jog it down and to the right so the pages are even. Check that the cover is against both right stops and tucked under the back stop. Make sure the toggle switch below the main power switch is up. Also check that your compressor is on and up to pressure and the pressure gauge's valve is in the open position.

Keep your hand above the book to prevent any of the pages from "floating" up. The clamp may squeeze air out from between the pages as it closes. Press START to cycle the machine. Lift the book off the nipper table as the clamp retreats. Inspect the book for proper alignment of the cover, even corners of the spine and adequate glue for both sides of the book. Do not open the pages yet. Allow time for the glue to cool and harden.

### ALIGNING THE COVER STOCK

To adjust the cover left or right, loosen and move the right stops left or right using caution. **THE RIGHT STOPS ARE VERY HOT!** Only loosen the hex screw in the center of each stop with the supplied 4mm T-handle Hex Key. Do not over tighten! To adjust the cover forward or back, loosen and adjust the Top Stop Guide (knob). (FIG #13)

### BOOK THICKNESS WHEEL & NIPPER ADJUSTMENT KNOB

The Book Thickness Wheel (Fig #15) adjusts the upward pressure of the nipper table to help produce a flatter spine. **For thinner books, turn it left. For thicker books, turn it right.** Normally books under ¼" would require a setting of 100 or higher. Half inch books should be set at 70. One inch or thicker should be set at 50 or slightly lower. These are average settings. You may require more or less pressure depending on your stock and covers. You may also make use of the Nipper Adjustment Knob to help produce squarer/sharper corners using the chart on the top plate of the nipper table (Fig #9).

Note, setting the nipper adjustment knob too tight may cause some sheets of the book to fold over. Simply open the nipper table further if this occurs. (FIG # 9 and #15)



Figure 15

### SIDE GLUE ADJUSTMENT

Keep in mind that **the glue pot and everything on it is extremely hot.**

**Make sure the glue level is within  $\frac{3}{4}$ " from the top of the glue pot.** Add glue chips as needed. Then try another book before making the following adjustments.

For more side glue on the non-operator side, loosen and move the Side Glue Wire closer to the rear side of the book. For less side glue, move it further away from the rear side of the book. (FIG #16)

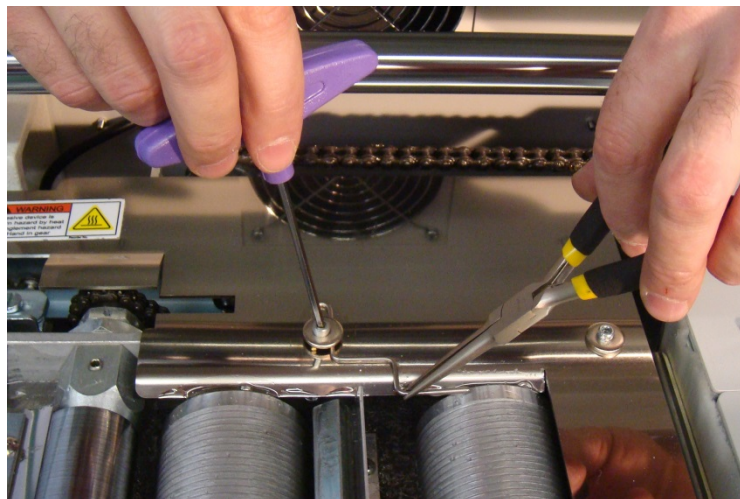

Figure 16

For more side glue on the operator side, you may need to adjust the Glue Pot's Metering roller down. Adjust the metering roller by loosening the set screw with the supplied 3mm t-handle hex key then placing the tip of the hex key into any of the holes in the nut located near the glue pot's drive chain. Rotate it towards the left (lower) to apply more glue or towards the right (higher) for less. The Book Thickness Wheel also affects the amount side glue that gets squeezed up. (FIG # 17)

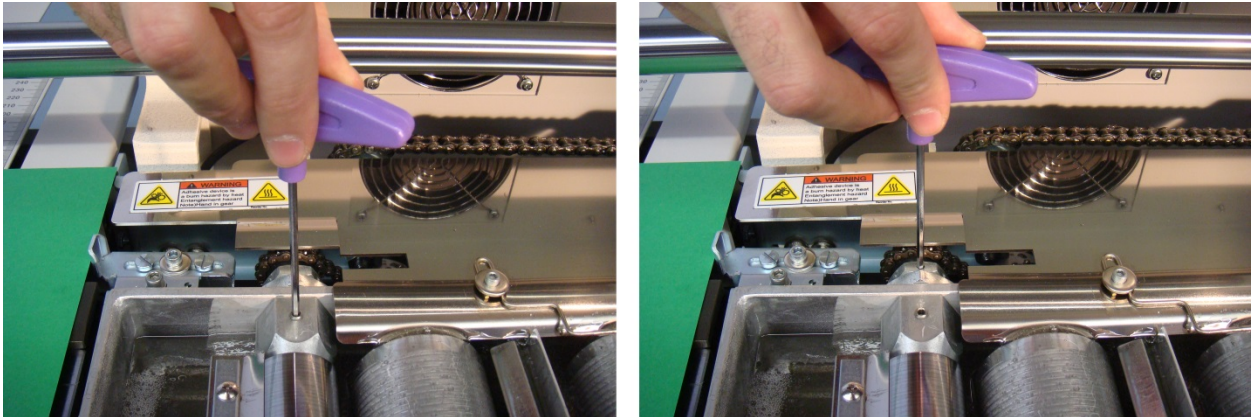

Figure 17

You may want to adjust the Nipper table's dwell time by pressing the SET button twice until you reach FINISH TIME then press the up or down arrows on the right side of the screen to increase or decrease how long the nipper squeezes the cover on the book. NOTE: If the Padding mode is on, 15 would equal 150 seconds. If the padding mode is off, then 15 would equal 4 seconds. We recommend setting the Finish Time to 15 for perfect binding books and 4 for pads. (More information for making pads is on page 13.)

Allow the book to cool a bit before inspecting it. Check that the side gluing is to your satisfaction inside the front and rear covers. Refer to the troubleshooting section starting on page 14 if these adjustments do not produce side glue to your satisfaction.

### ADJUSTING THE STRENGTH OF THE BIND

**Before making adjustments to the roughing wheel and/or notching pins, turn off the roughing motor by flipping the toggle switch off. Locate it below the main power switch.**

Paper grain direction should follow along the length of the spine. This will add strength to your bind. After the book has sat for an hour, you may check the binding strength. If the pages pull straight out easily, you may need to raise the notching pins or add more glue to the spine by lowering the Metering Roller or adjusting the Book Thickness Wheel. The Roughing Wheel should not need to be adjusted. They are set to rough, not cut the pages. The Notching Pins can be set higher for certain heavier/glossier stock that tends to repel the glue. When raising the Notching Pins, do not allow them to cut more than 1/16" into the

book. Also make sure they do not hit the guards. Please refer to the troubleshooting section starting on page 14 for more details.

### GETTING INTO PRODUCTION

Once the settings are to your satisfaction place the next book body into the clamp, jog it down and toward the right. Place the cover stock squarely on the nipper table with the rear edge tucked under the Top Stop Guide. Then simply press START.

If you have a **DIGIBINDER PLUS**, turn on the Vacuum motor by flipping the **green** toggle switch on the front of the machine.

### MAKING PADS

If you are making pads, be sure to flip the toggle switch below the main power switch down to turn off the roughing motor. Press the SET button for the PADDING MODE screen then press X to toggle it on or off. Padding On will disable the Nipper Table and the cover stock sensor. Press SET again then Up or DOWN arrows to set the length of the finish time. **NOTE:** If the Padding mode is on, 15 would equal 150 seconds. If the padding mode is off, then 15 would equal 4 seconds. Press SET twice to return to the temperature screen. **TIP:** If you prefer using the nipper table for pads, leave the padding feature off and block the sensor on the nipper table. Use of any non-stick spray is recommended to prevent glue from sticking to the table. **\*Do not make pads while using iGlue.\***

### DRAINING THE GLUE

After a period of time, the glue may get dirty or burnt or you may need to change the type of glue you are using. To drain the glue, remove the front panel, being careful not to damage the control panel wires, to locate the drain. Place a box under the drain chute and remove the Allen screw. USE CAUTION: Drain chute, Allen screw and glue are extremely hot! When the glue has been drained you may melt wax in the glue pot to remove any excess glue and clean out any paper dust at the bottom. (FIG #18)

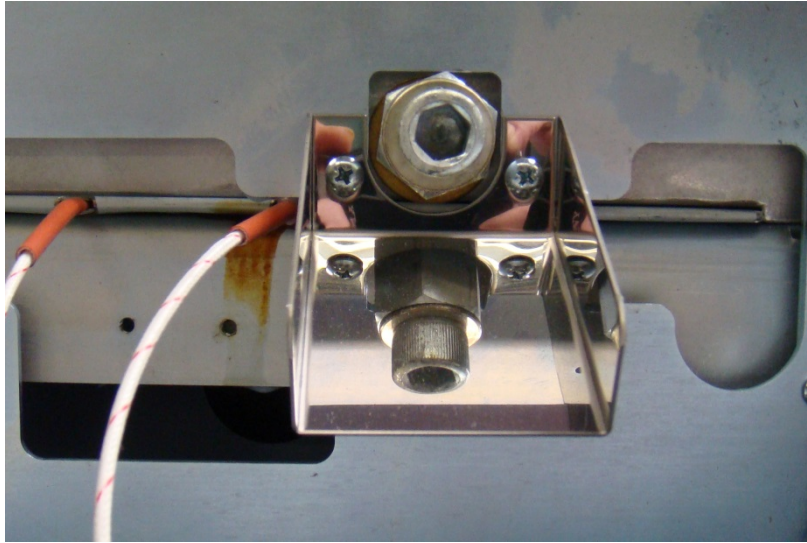

Figure 18

### DAILY MAINTENANCE

The glue level in the pot will go down as books are bound. Glue chips should be used to replenish the pot as needed. If you see a dry spot or large air pocket on the center glue roller, add more glue. The level of the glue should rise to about 3/4" below the top of the glue pot.

Do not leave the machine powered on when not in use. This will cause the glue to burn and darken. If reheating is too time consuming, press the **O** button on the control panel to put the machine into **Stand-By** mode. This will lower the glue temperature to prevent burning. Press **O** again to resume.

Use the supplied air gun to blow paper dust away from the glue pot.

**The front and rear shafts must be cleaned regularly** to allow smooth operation of the clamp. Solvents or penetrating oils may be used to remove any glue residue. The shafts must be clean and slick so the clamp doesn't get bogged down or stuck during operation.

### WEEKLY MAINTENANCE

Check that the Notching Pins are sharp to avoid straining of the roughing motor and to ensure clean notching for adequate glue penetration. When replacing dull Notching Pins, follow the instructions in the Troubleshooting Section of this manual under **ROUGHING BLADE & NOTCHING PIN ADJUSTMENT**.

**Air Compressor:** The compressor should be bled weekly to remove moisture build up inside the tank. The bleed valve is located at the bottom of the compressor tank. Check the oil level in the sight glass of the compressor motor. If oil is not visible or low, add **air compressor oil** into the motor's tube by removing the rubber cap (opposite side from the filter). Also check that the filter isn't clogged. To avoid overheating, do not operate the compressor in an enclosed area and check for air leaks periodically. Make sure the compressor is off when not in use.

## TROUBLE SHOOTING

---

Some adjustments require the Digibinder to be in the SETUP mode. This is done by turning off the Digibinder then, while holding down the CLAMP button, turn the power back on. **\*\*Note:** The machine will cycle continuously if the START button is pressed. Press and hold the X button while the clamp is traveling to the right to stop the cycling or press the Emergency Stop button. **Also, while in Setup Mode, the O (Stand By) button will turn on the roughing motor.** Pressing the X button will stop the motor. **Flip the toggle switch below the Main Power Switch to turn off the Roughing Motor.** CAUTION: Pressing the RIGHT arrow button will close the roughing blade guard. To reset the machine back to normal operation, simply turn the machine off then on again.

### UNEVEN OR INCONSISTENT SIDE GLUE

Make sure the glue pot has enough glue. While the rollers aren't cycling, the glue level should be about  $\frac{3}{4}$ " below the top of the glue pot. Check that the Air Compressor is on and up to pressure. There should be between 90 – 110 psi. You may also need to level your nipper table. See Leveling the Nipper Table on page 16.

### ADJUSTING SIDE GLUE BETWEEN HEAD AND FOOT OF BOOK

1. Put the Digibinder in SETUP Mode. The clamp will close and the roughing blade's guard bracket will open.
2. Open the clamp and place a cover sheet in it, making sure the bottom doesn't curl as the clamp closes. Close the clamp then jog it, using the left and right arrow buttons, back and forth over the Glue Pot's Metering roller. Check the distance from the bottom of the cover stock to the roller. The cover stock must be the same distance above the roller from the leading edge to the trailing edge.

3. Locate the screws on the topside of the register table where you place the books. Level one end of the register table by turning the screws clockwise to lower or counterclockwise to raise it using a 5mm hex key.

4. Reset the machine back to normal operation simply by turning the machine off then on again after completing adjustments, then test by binding a book. If the table is leveled but the side gluing still isn't even, you may need to level the nipper table. See Leveling the Nipper Table below.

### **ADJUSTING SIDE GLUE ON OPERATOR AND NON-OPERATOR SIDES OF THE BOOK**

**CAUTION:** Burn Hazard.

Because the rear nipper table comes in before the front table does, more glue is channeled towards the front of the book. Adjust the Metering roller until you have enough side glue between the cover and the 1st page of the book (operator side). Then locate the side glue wire on top of the far right glue roller. Press the **Emergency Stop** button. Loosen the screw then, using a pair of needle nose pliers, move the Side Glue Wire slightly closer to the book to apply more or further away for less side glue between the cover and last page (non-operator side) of the book. Release the Emergency Stop button by giving it a gentle twist clockwise.

### **PAGES NOT BINDING WELL**

The glue needs time to cool and harden. Let them sit an hour before checking the binding strength. If the pages still come out too easily then it may need deeper roughing and/ or notching, more glue, more nipper pressure, a longer nipper dwell time or special glue for your product.

**TIP:** The grain direction of the paper and cover stock should follow the length of the book's spine. This will improve the binding strength by as much as 25%. Fold the stock in half, length wise then width wise, and see which fold looks cleaner/smooth. The smoother fold is the grain direction. You may also try one of these other solutions:

1. Increase the nipper finish time. Press the SET button twice to get to the Finish Time screen. Use the UP arrow button to increase the Finish Time.
2. Increase the nipper pressure by slightly turning the **book thickness wheel** to the left. Be sure not to use too much pressure. This will squeeze out the glue from the spine or cause "nail heading".
3. Increase the amount of glue being applied by lowering the far left glue metering roller. The glue level in the pot will go down as books are bound. Glue chips should be used to

replenish the pot as needed. If you see a dry spot or large air pocket on the center glue roller, add more glue. The level of the glue should rise to about 3/4" below the top of the glue pot.

4. Pull a page out of the book and check the depth of the notches. If they are barely visible then you need to raise the notching pins. Adjust the roughing and notching. (See Roughing Blade and Notching Pin Adjustment below) Heavier stock or coated materials need deeper notching and a longer nipper finish time. \*Note: Notching pins must be sharp!

### ROUGHING BLADE AND NOTCHING PINS ADJUSTMENT

1. Remove the operator side guard from the top of the roughing blade.
2. Put the Digibinder in SETUP mode as described at the beginning of this Troubleshooting section. **Turn off the Roughing motor** by flipping the toggle switch below the main power switch.
3. Remove the front panel/guard. Be careful not to pull the wires of the display/control panel board.
4. Open the clamp and place a cover sheet in it, making sure the bottom doesn't curl as the clamp closes. Close the clamp then jog it over the roughing blade using the left and right arrow buttons. **Press the Emergency Stop Button.**
5. Loosen the setscrews locking the roughing blade assembly to the motor's shaft (under the blade assembly) with the supplied T-handle hex key. (FIG #18)

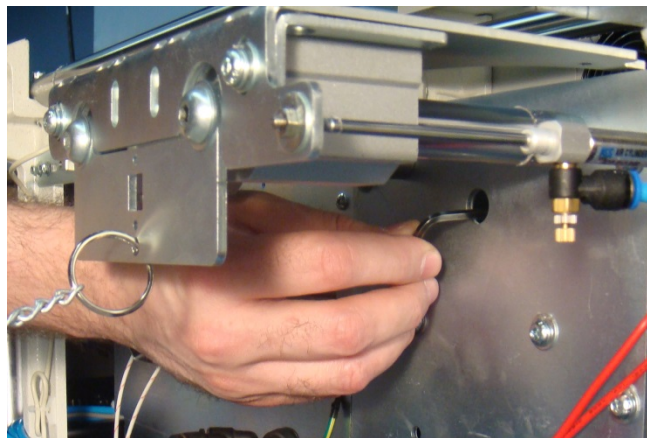

Figure 19

6. Adjust the roughing blade's height so that the tips of each tooth just lightly touch the pages. Lock the setscrews once the correct height is set.

7. Adjust the notching pins so that it goes no more than 1/16" into the pages. Loosen setscrews on the outside of the roughing blade assembly with a 2.5mm hex key. You may need to raise it a bit more for heavier or coated stock. \*Note: The notching pins may fall out once the setscrews are loosened. (FIG #19)

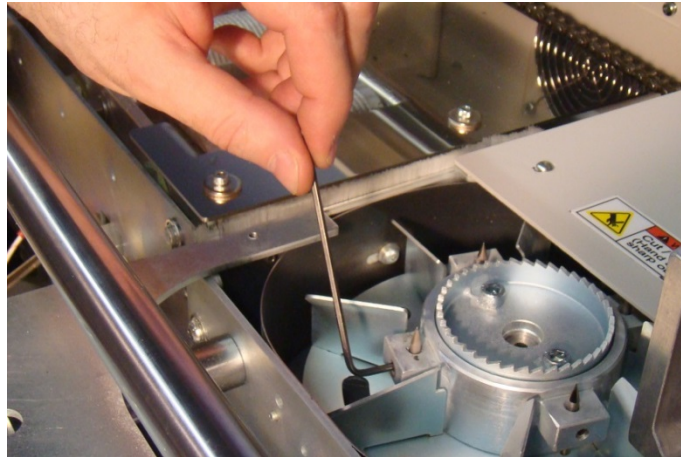

Figure 20

8. Install the blade's guard and check that the roughing blade and notching pins do not interfere with the guards by turning the blade by hand.

9. When you are done making adjustments, turn the machine off then on again to return it to normal operation. Install all guards and release the Emergency Stop button.

### **UNEVEN CORNERS ON THE BOOK SPINE**

Make sure the compressor is turned on, up to pressure and the Air Compressor's valve where the machine's air hose is connected is in the fully open position. Make sure the bleed valve at the bottom is fully closed. The pressure gauge's needle should point approximately .75 MPa or 110 PSI (between 11 and 1 o'clock). Make sure the air hose isn't pinched or kinked.

If you have the correct air pressure and the corners still aren't even, then you may need to level the nipper table. If one or both ends of the book have very sharp corners, try lowering the book thickness wheel a bit.

### **LEVELING THE NIPPER TABLE**

1. Press the 1st and 2nd buttons on the control panel (top left buttons) to raise and close the nipper table. Remove the small front white cover stock support tray.
2. Remove Rear Table Cover Support only if you need to adjust the rear right side of the nipper table. You can adjust the rear setscrew on the left side without removing this tray.

3. Loosen 2 locking screws at the corner you want to adjust with the supplied 4mm T-handle hex key.

4. Turn the adjustment setscrew with a 2.5mm hex key clockwise to raise or counterclockwise to lower that corner. \*Note: You should adjust the front and rear (operator and non-operator side) set screws the same amount on either the left or right side of the nipper table. When lowering a corner, press down slightly on that corner while tightening the two 4mm locking screws. (FIG #19)

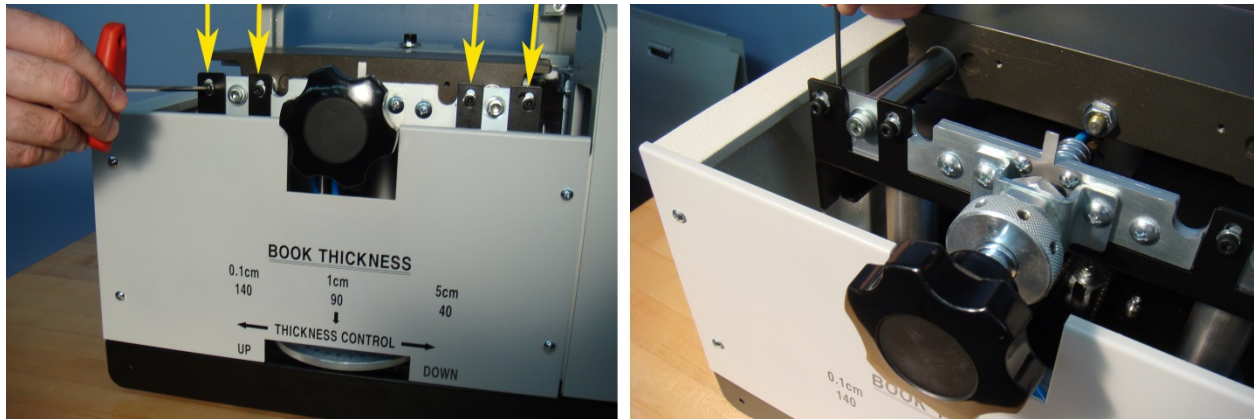

Figure 21

### MACHINE DOES NOT CYCLE

Make sure the machine is up to temperature and the green lamp on the control panel is lit. It takes approximately 45 minutes to reach operating temperature before it will allow you to operate.

Check that the Set temp and actual temp are over 130 degrees Celsius.

### MACHINE BEEPS TWICE IN RAPID SUCCESSION AND DOES NOT CYCLE

Make sure the book is in the clamp and a cover sheet is on the nipper table and both are jogged all the way to the right and blocking the sensors. Some dark stocks may not activate the sensor(s).

### CLAMP IS STUCK / ERROR MESSAGE

Most problems can be solved over the phone but you may need to schedule a service call. Write down the error message and machine serial number and call your dealer.

The front and rear shafts must be clean and slick or the clamp will get stuck. It is recommended that you clean the shafts daily. You may use solvents or penetrating oil to clean any paper dust or glue residue from the shafts. **CLEAN THE SHAFTS DAILY.**

# STERLING DIGIBINDER ELECTRICAL SCHEMATIC

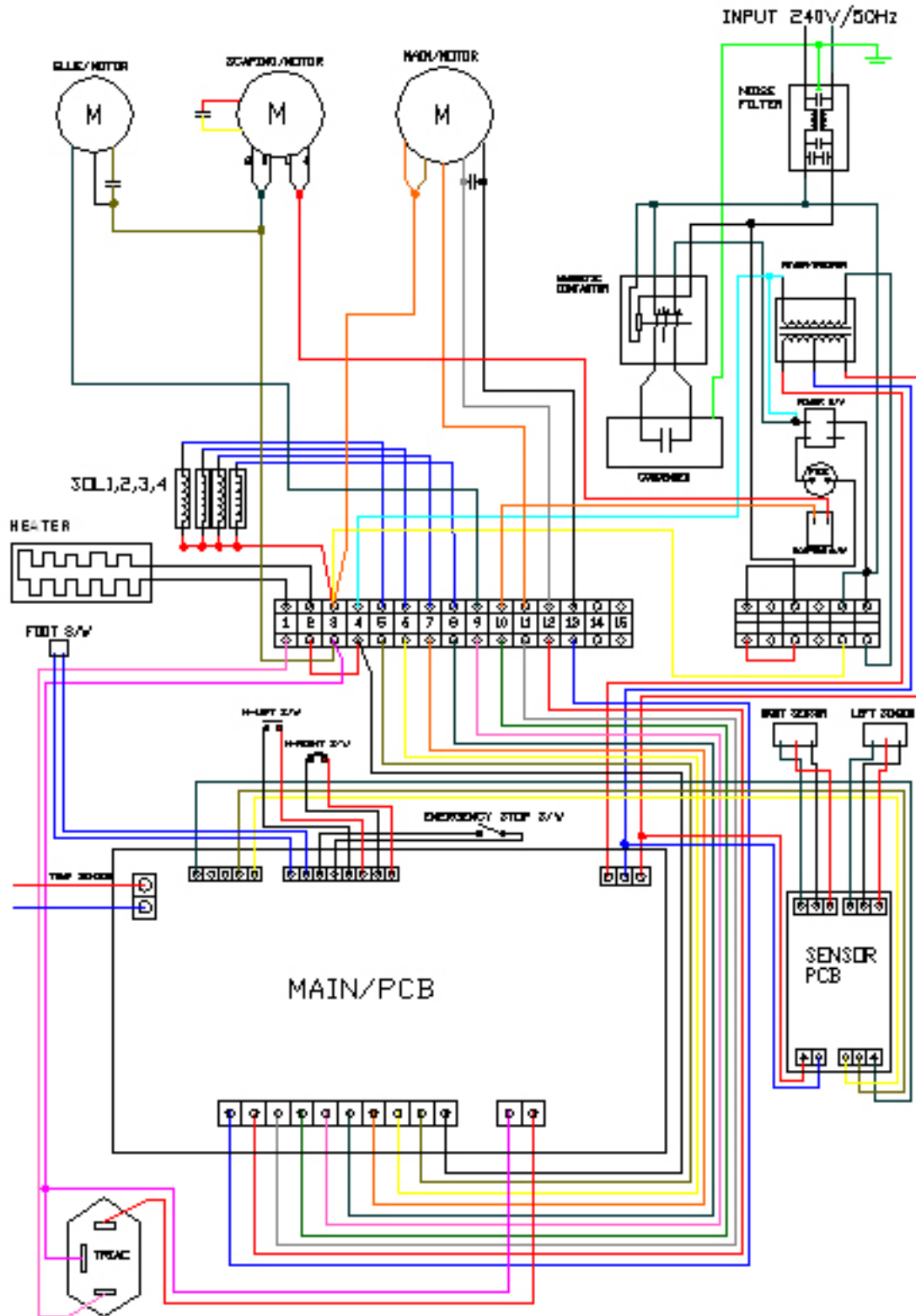

# STERLING DIGIBINDER PLUS ELECTRICAL SCHEMATIC

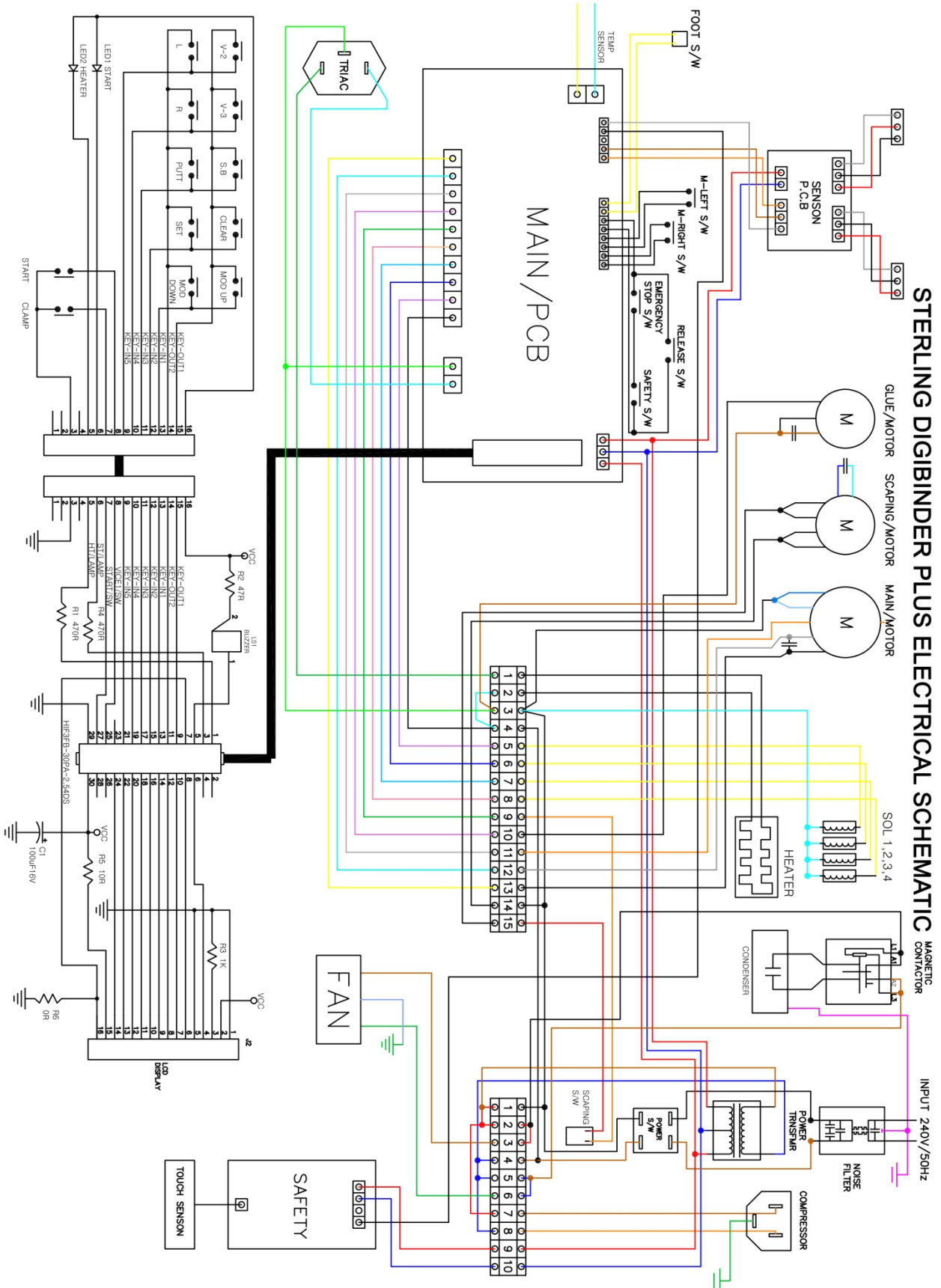



## **THE STERLING DIGIBINDER PLUS PARTS MANUAL**



**SPIEL**  
ASSOCIATES, INC.

TEL: 718-392-7900

FAX: 718-729-5067

45-01 Northern Blvd. Long Island City, NY 11101  
[www.spielassociates.com](http://www.spielassociates.com)

NO	Tachoplus Code	Description	Quantity
	77.1010	Screw for outlet	1
	77.1015	Outlet nut	1
	77.1020	Glue outlet	1
	77.1030	Heater Plate	1
	77.1040	Temperature sensor cpl.	1
	77.1080	Main chain	1
	77.1090	Glue pot chain	1
	77.1100	Height control handle chain	1
	77.1120	Main chain connecting supporter	1
	77.1130	EL 1/8-6(ROHS)	1
	77.1140	Filter	1
	77.1150	Solenoid valve	1
	77.1160	Sensor clamp	1
	77.1165	Sensor clamp cable 196cm	1
	77.1170	Slide bearing cpl.	1
	77.1180	Left vise clamp all cpl.	1
	77.1190	Nipping plate front	1
	77.1200	Right vice cylinder	1
	77.1210	Cylinder (B30-S100 or B32-S100)	1
	77.1220	Cylinder (B40-15)	1
	77.1230	Pressue control gauge	1
	77.1240	Main chain connection assy.	1
	77.1245	Chain connector	1
	77.1250	Doctor roller scraper	1
	77.1260	Middle glue roller scraper cpl.	1
	77.1270	Side glue guide	1
	77.1280	First glue roller	1
	77.1290	Middle glue roller	1
	77.1300	Doctor roller	1
	77.1310	Nipping plate back	1
	77.1350	Relay, high voltage	1
	77.1360	Noise Filter	1
	77.1380	Triac	1
	77.1390	Trafo	1
	77.1400	Main PCB	1
	77.1410	PCB cover	1
	77.1500	Sensor PCB	1
	77.1601	LCD panel	1
	77.1611	Display data cable(NEW)	1
	77.1630	Gear f. table height adjustment	1
	77.1725	Panel unit (new Ver)	1
	77.1730	Set of end Step Switches	1
	77.1740	Main motor(S9R40GXH-CE)	1
	77.1750	Glue pot motor	1
	77.1760	Scarping motor	1
	77.1840	Back stop assy cpl.	1
	77.1850	Air pistol	1
	77.1860	Paper guide plate	1
	77.1865	Power cord	1
	77.1920	Air filter	1
	77.1931	Clamp stop bolt	1
	77.1941	Clamp stop bar	1

77.1960	Emergency stop switch	1
77.1971	Main switch	1
77.1980	Switch for slitting tool	1
77.2020	End stop spring cpl.	1
77.2050	Exhauster	1
77.2070	Safety device sensor bar	1
77.2080	Safety device PCB	1
77.2090	Connection sensor Bar to PCB	1
77.2120	On/off-switch for exhauster	1
77.2170	Safety hood	1
B770820	Solenoid valve Set	1
B770910	Main Switch tool	1
B771620	Glue Pot	1
B771940	Wrench Set	1
B772110	Compressor	1
77.7100	Scarping motor	1
77.7110	Slide shaft	1
77.7120	Scarping cover cylinder	1
77.7130	Cover slide bearing	1
77.7140	Slit/Fan housing box	1
77.7150	Slit tool	1
77.7160	Dusty filter	1
77.7200	Scarping cover	1
77.7210	Bearing fixing plate	1
77.7220	Scarping middle cover	1
77.7230	Sensor bracket	1
77.7240	Scarping back cover	1
77.7250	Scarping front cover	1
77.7260	Dusty gear board	1
77.7270	Brush fixing board	1
77.7280	Scarping cover cylinder fixing bracket	1
77.7290	Dusty vacuum box	1
77.7300	Sucking box	1
77.7310	Scarping fan	1
77.8100	Safety cover	1
77.8110	Safety cover PC board	1
77.8120	Safety cover handle	1
77.8130	Cover fixing pin(right)	1
77.8140	Cover fixing pin(left)	1
77.8150	Safety cover sensor	1
77.8240	Main chain gear fixing board	1
77.8250	Safety key switch	1
77.8500	Front cover case	1
77.8510	Front cover case fixing ring	1
B780310	Scarping cpl.	1
B782200	Safety cover cpl.	1

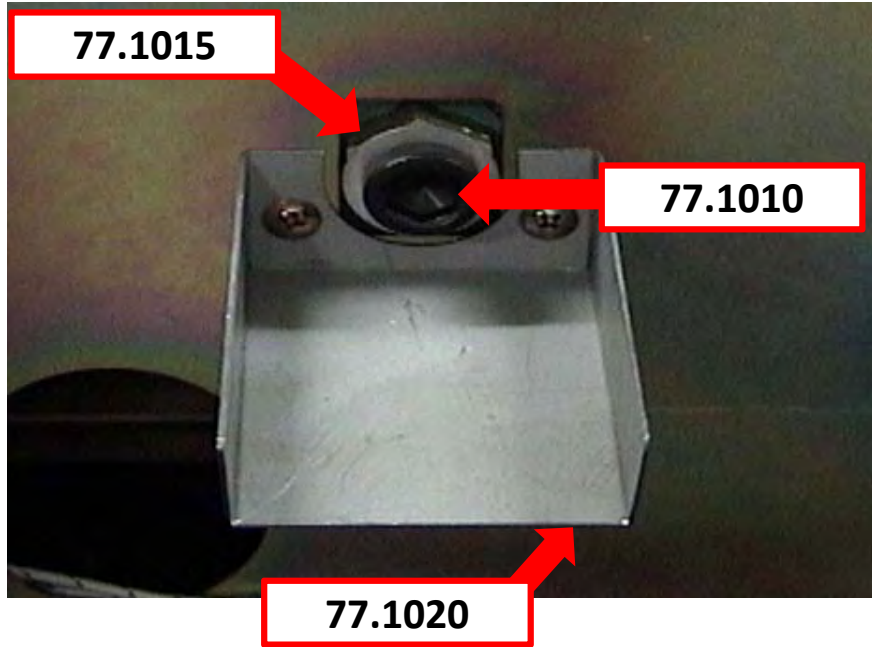

NO	Tachoplus Code	Description	Quantity
	77.1010	Screw for outlet	1
	77.1015	Outlet nut	1
	77.1020	Glue outlet	1
	77.1030	Heater Plate	1
	77.1040	Temperature sensor cpl.	1

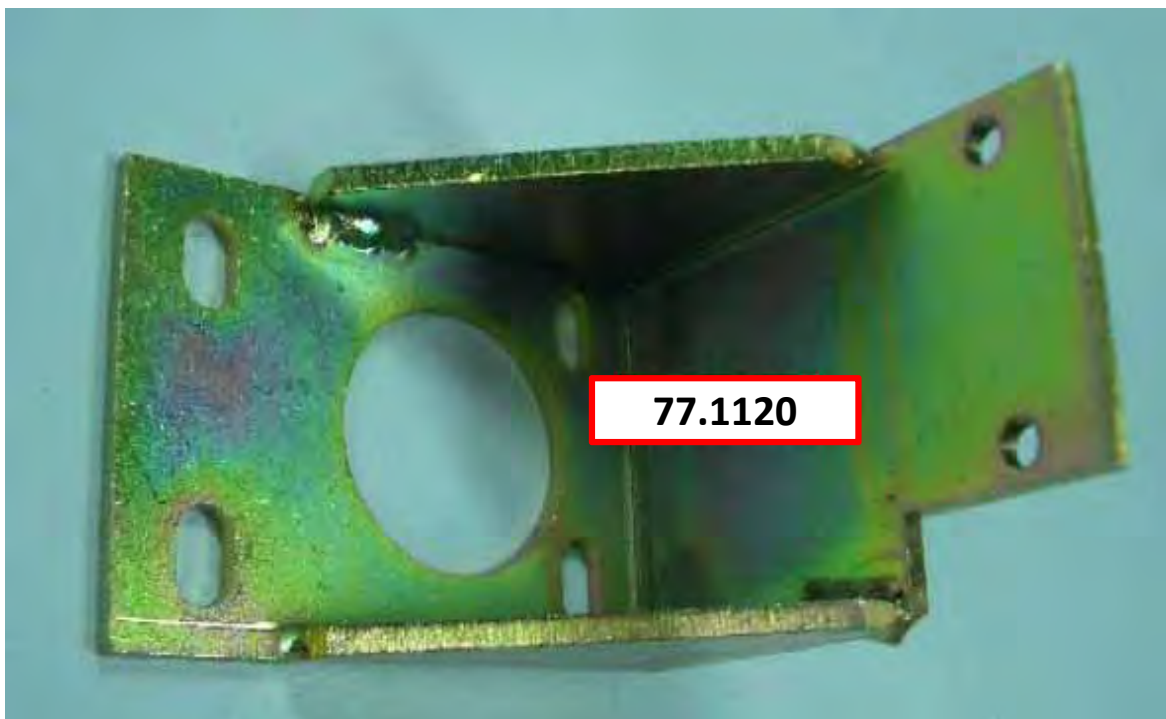
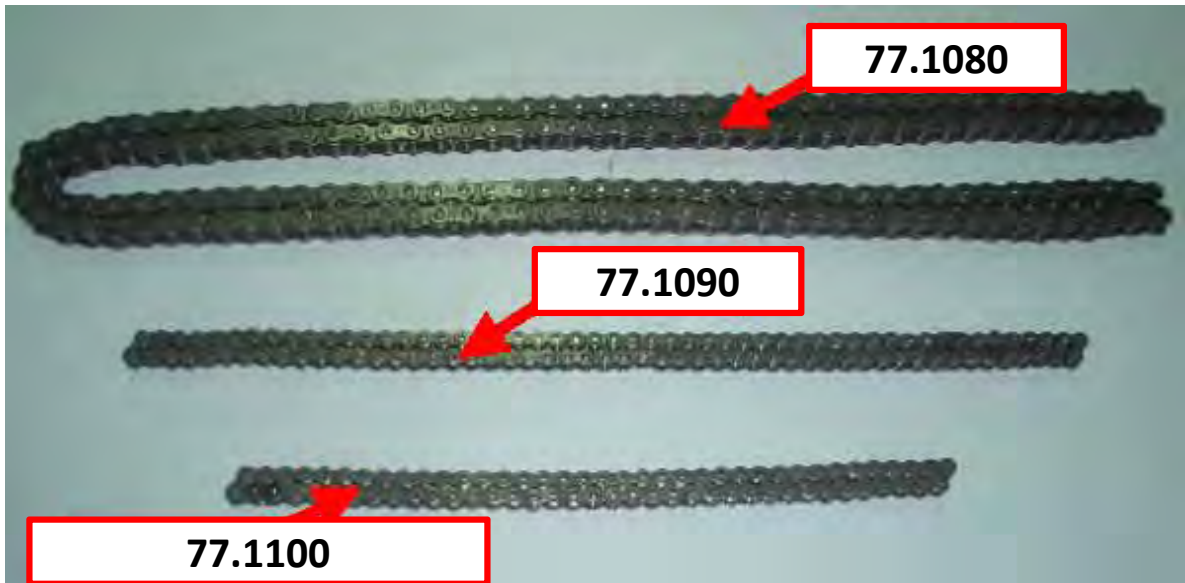

NO	Tachoplus Code	Description	Quantity
	77.1080	Main chain	1
	77.1090	Glue pot chain	1
	77.1100	Height control handle chain	1
	77.1120	Main chain connecting supporter	1

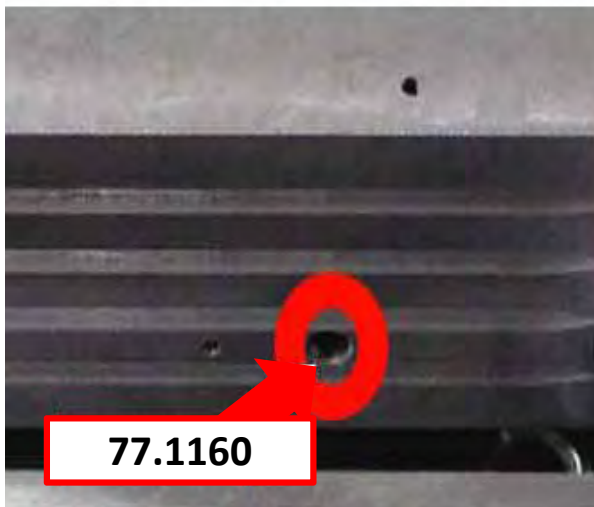
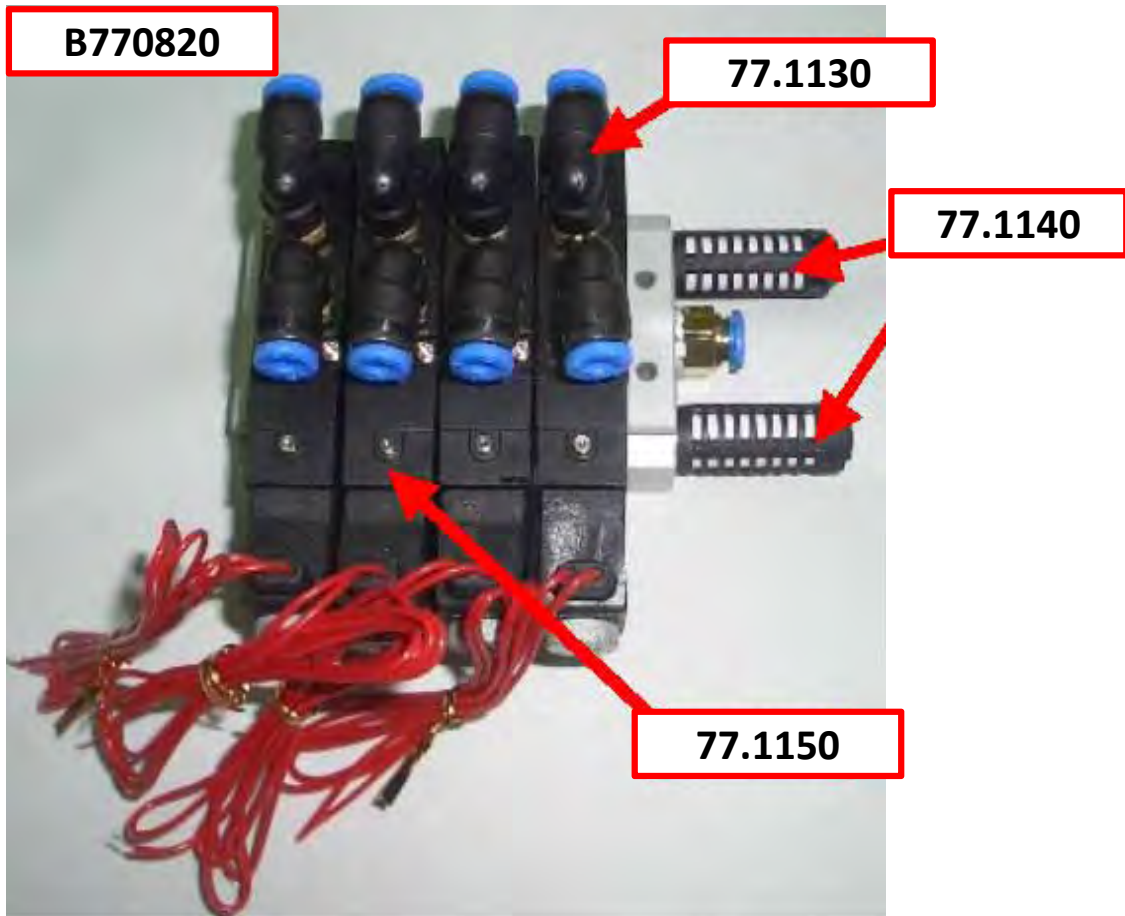

NO	Tachoplus Code	Description	Quantity
	77.1130	EL 1/8-6(ROHS)	1
	77.1140	Filter	1
	77.1150	Solenoid valve	1
	77.1160	Sensor clamp	1
	77.1165	Sensor clamp cable 196cm	1
	B770820	Solenoid valve Set	1

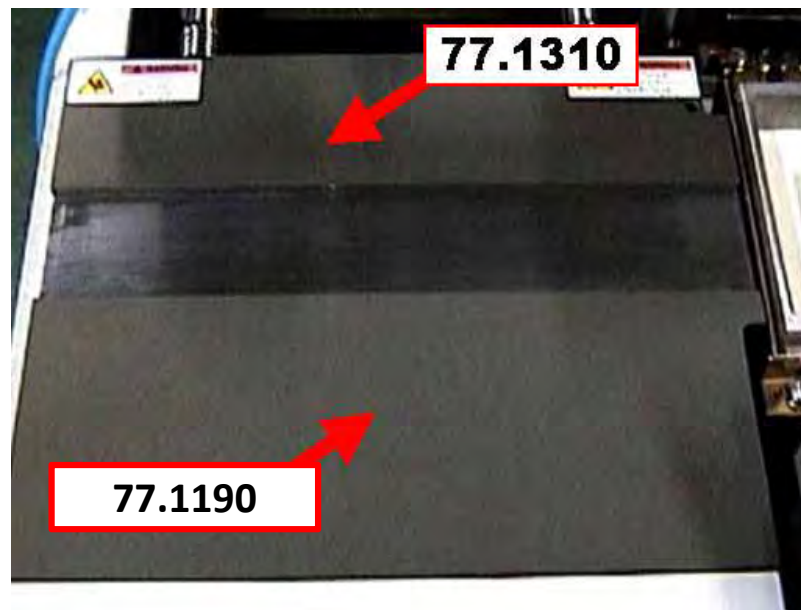

NO	Tachoplus Code	Description	Quantity
	77.1170	Slide bearing cpl.	1
	77.1190	Nipping plate front	1
	77.1200	Right vice cylinder	1
	77.1310	Nipping plate back	1

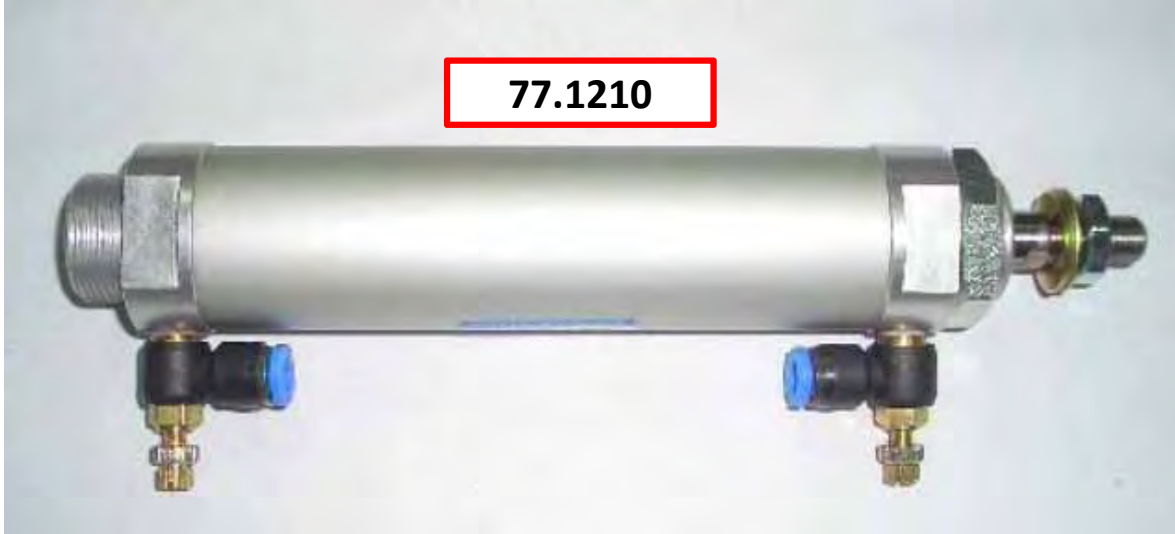

NO	Tachoplus Code	Description	Quantity
	77.1210	Cylinder (B30-S100 or B32-S100)	1
	77.1220	Cylinder (B40-15)	1



NO	Tachoplus Code	Description	Quantity
	77.1230	Pressue control gauge	1
	77.1240	Main chain connection assy.	1
	77.1245	Chain connector	1

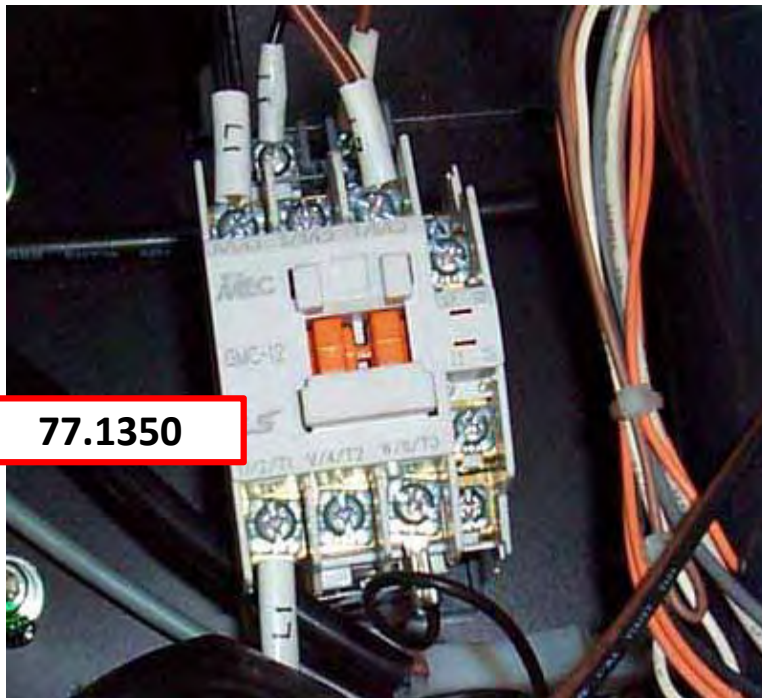
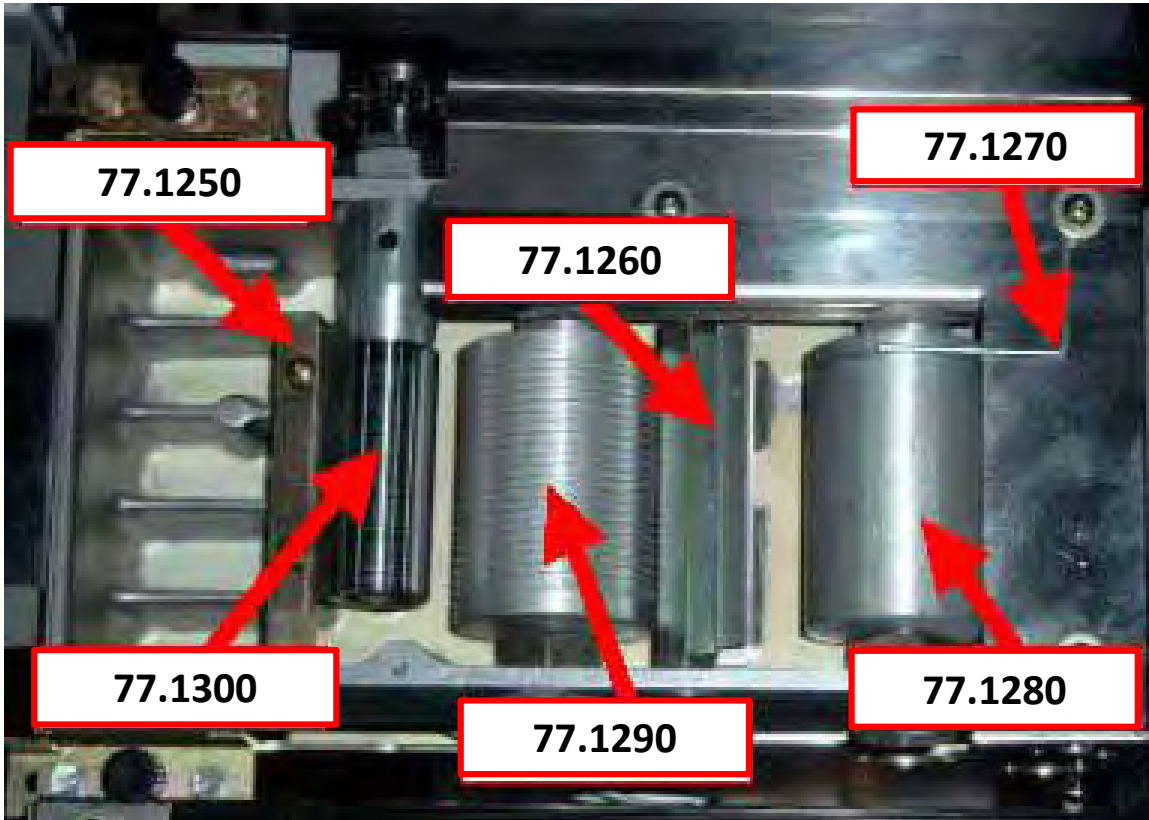

NO	Tachoplus Code	Description	Quantity
	77.1250	Doctor roller scraper	1
	77.1260	Middle glue roller scraper cpl.	1
	77.1270	Side glue guide	1
	77.1280	First glue roller	1
	77.1290	Middle glue roller	1
	77.1300	Doctor roller	1
	77.1350	Relay, high voltage	1

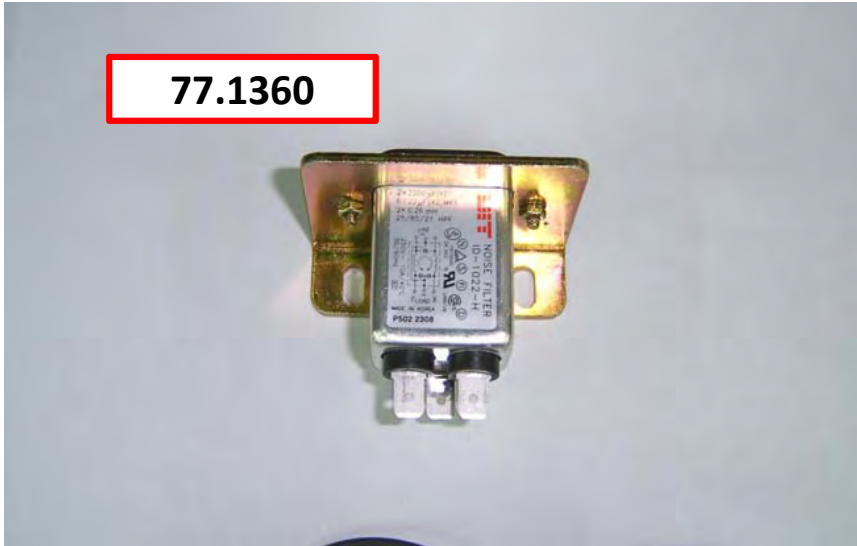

**77.1360**

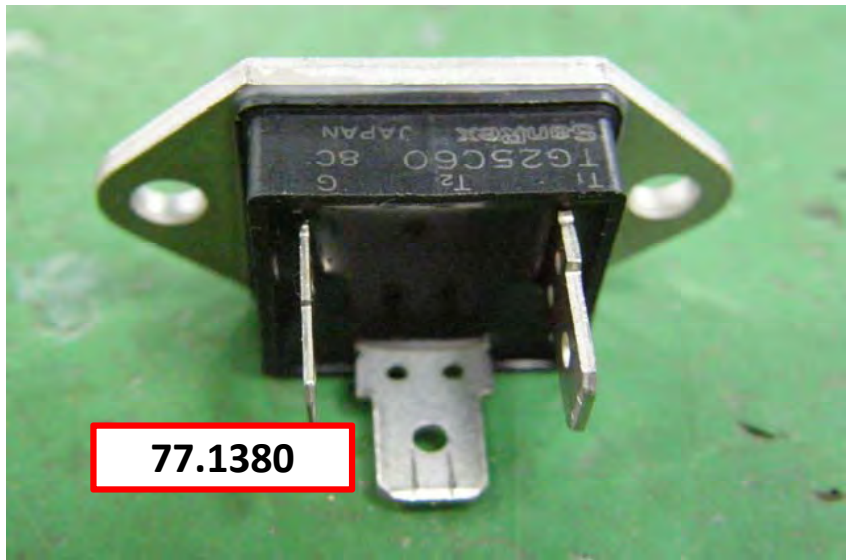

**77.1380**

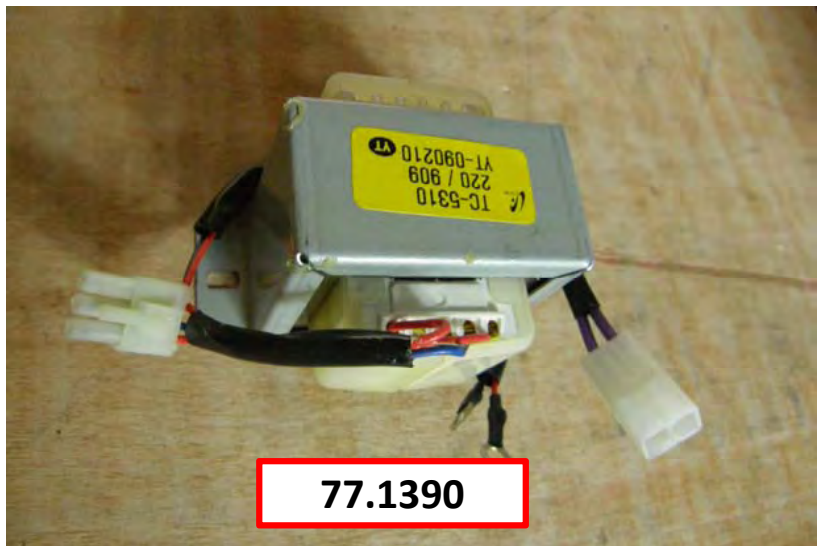

**77.1390**

NO	Tachoplus Code	Description	Quantity
	77.1360	Noise Filter	1
	77.1380	Triac	1
	77.1390	Trafo	1

**77.1400**

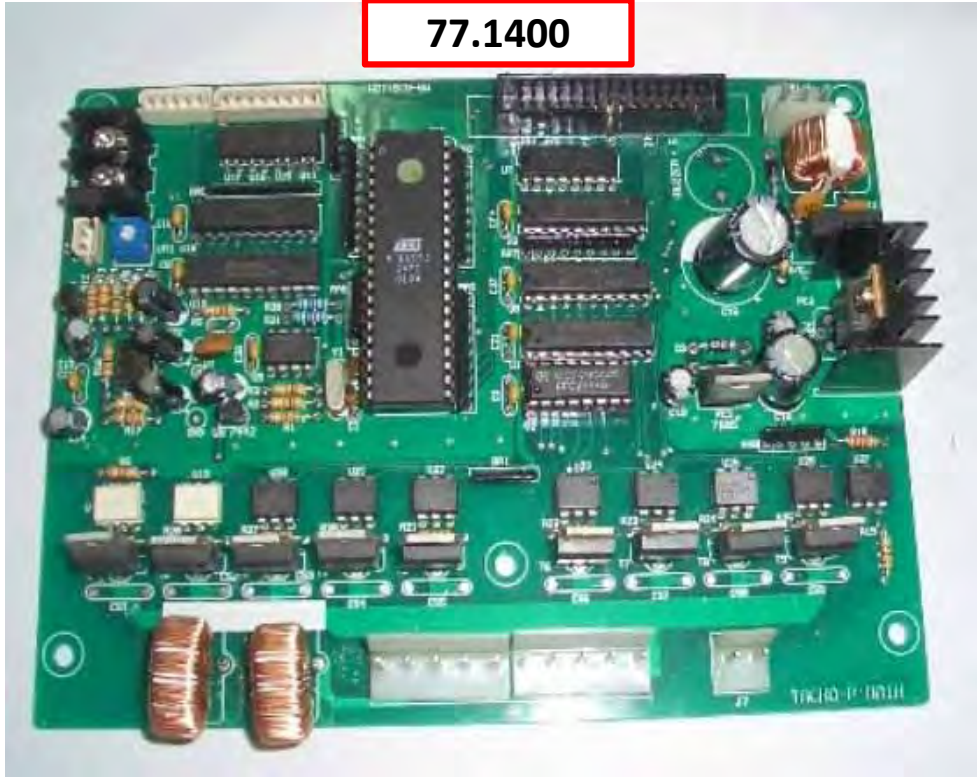

**77.1500**

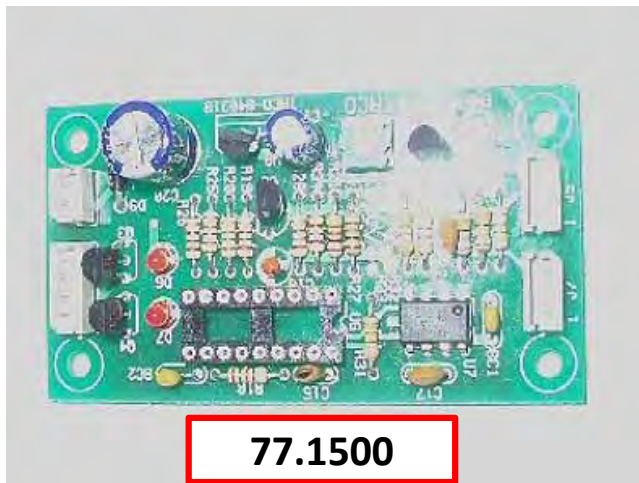

NO	Tachoplus Code	Description	Quantity
	77.1400	Main PCB	1
	77.1410	PCB cover	1
	77.1500	Sensor PCB	1

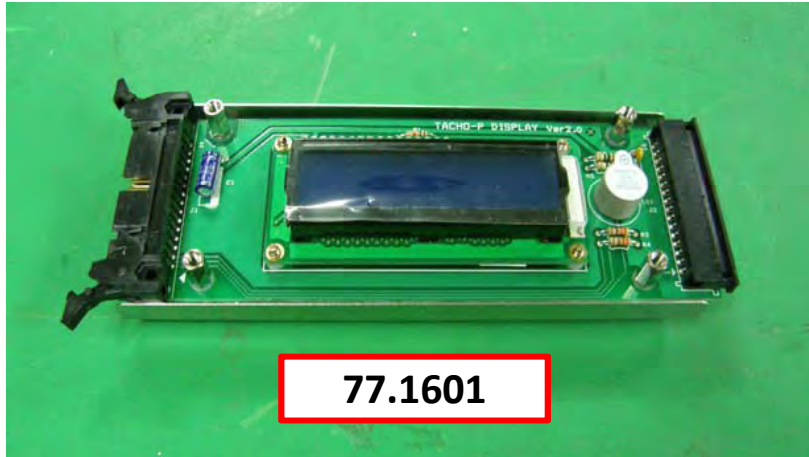

**77.1601**



77.1611

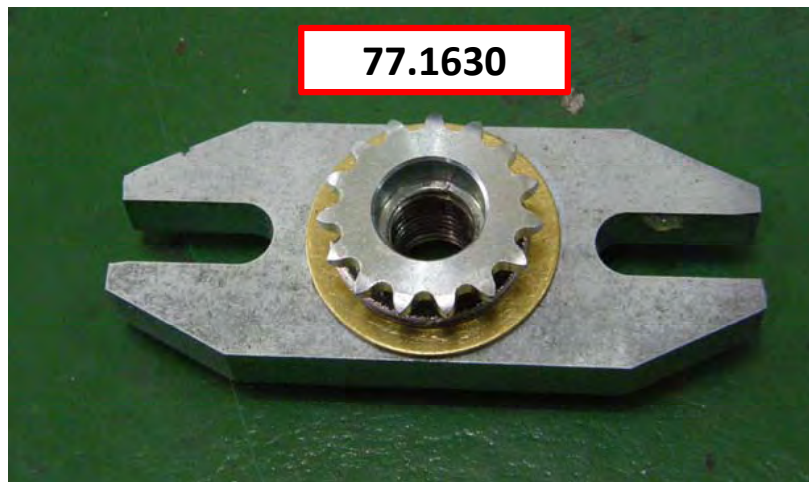

**77.1630**

NO	Tachoplus Code	Description	Quantity
	77.1601	LCD panel	1
	77.1611	Display data cable(NEW)	1
	77.1630	Gear f. table height adjustment	1

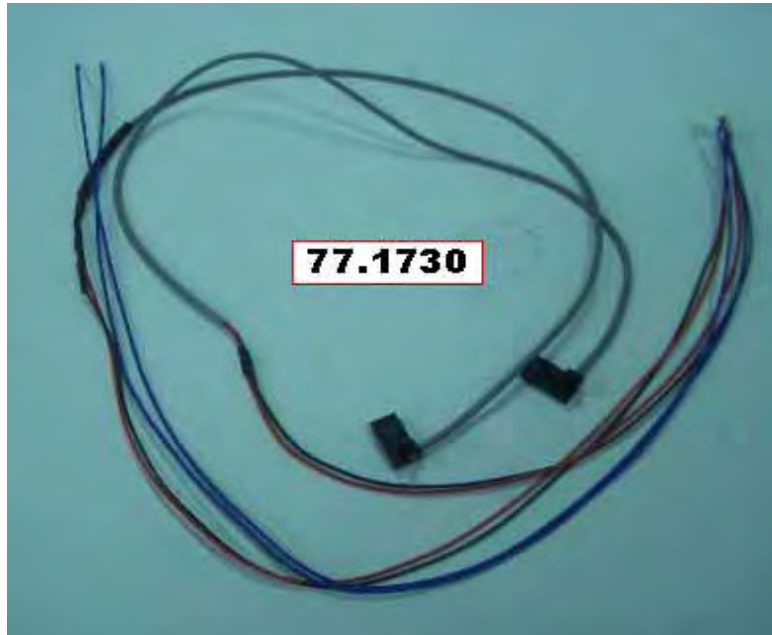

NO	Tachoplus Code	Description	Quantity
	77.1725	Panel unit (new Ver)	1
	77.1730	Set of end Step Switches	1
	77.1740	Main motor(S9R40GXH-CE)	1

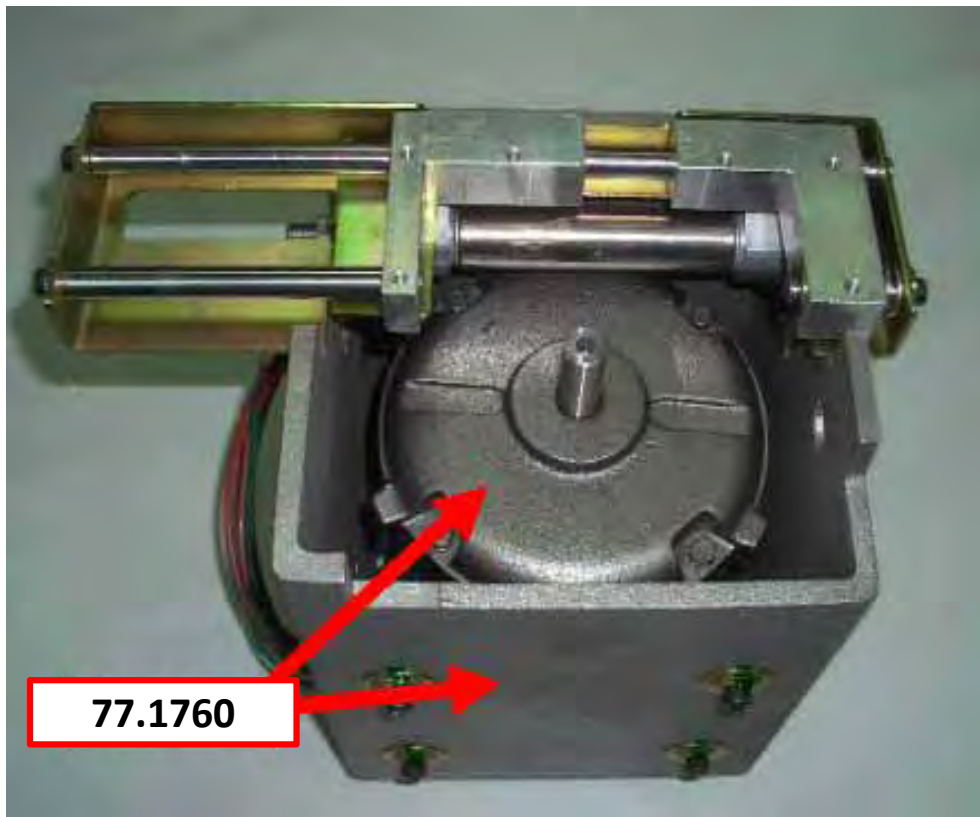
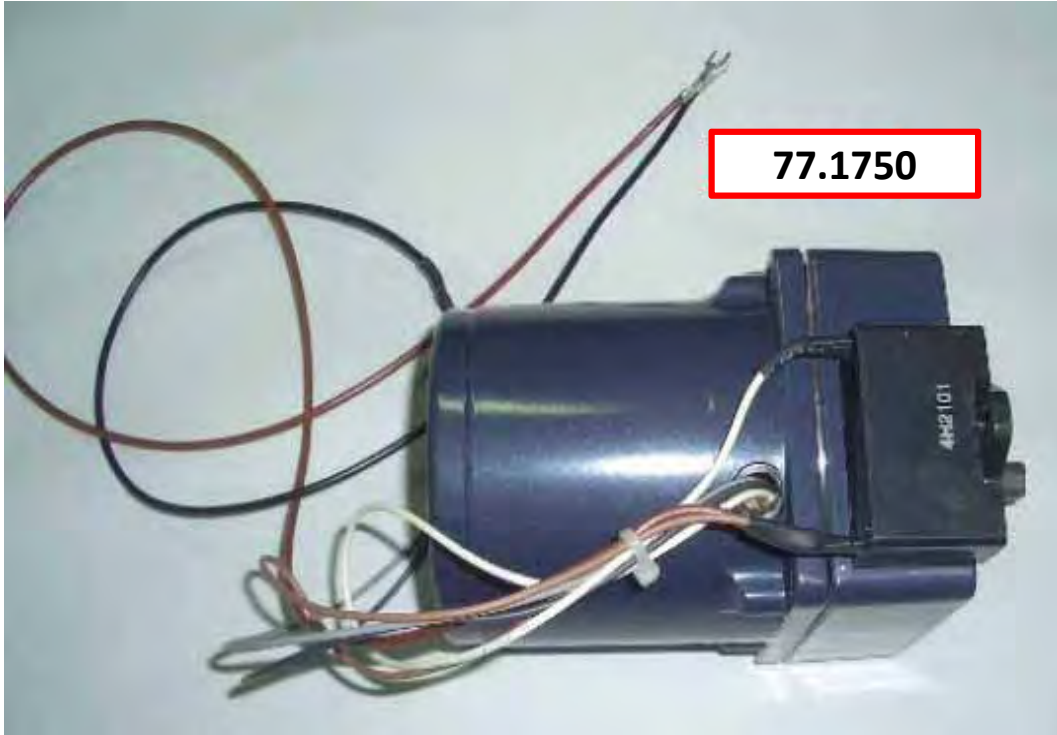

NO	Tachoplus Code	Description	Quantity
	77.1750	Glue pot motor	1
	77.1760	Scarping motor	1

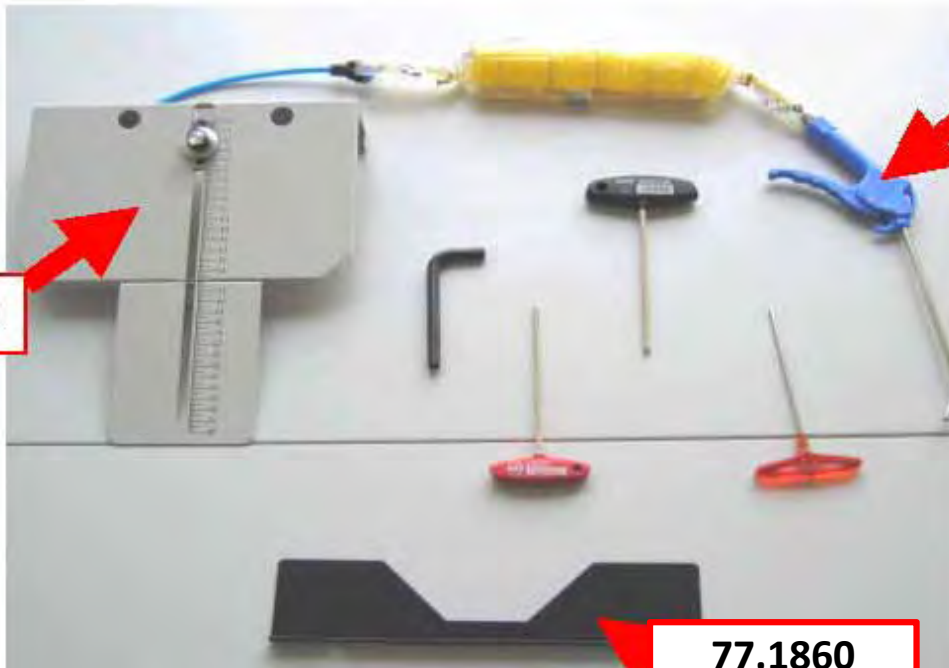
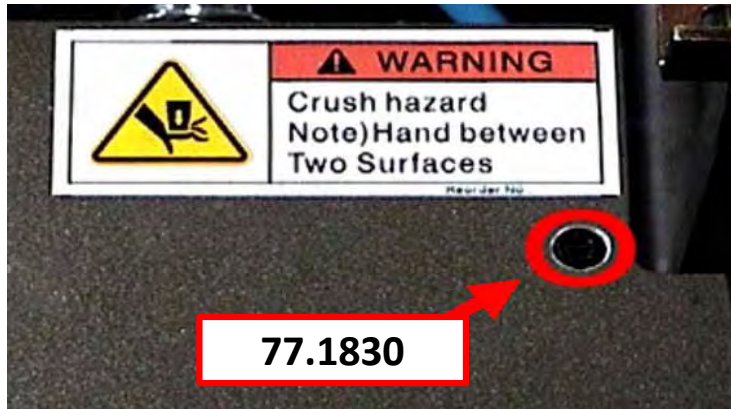

NO	Tachoplus Code	Description	Quantity
	77.1830	Sensor cover (left)	1
	77.1840	Back stop assy cpl.	1
	77.1850	Air pistol	1
	77.1860	Paper guide plate	1
	77.1865	Power cord	1
	B771940	Wrench Set	1

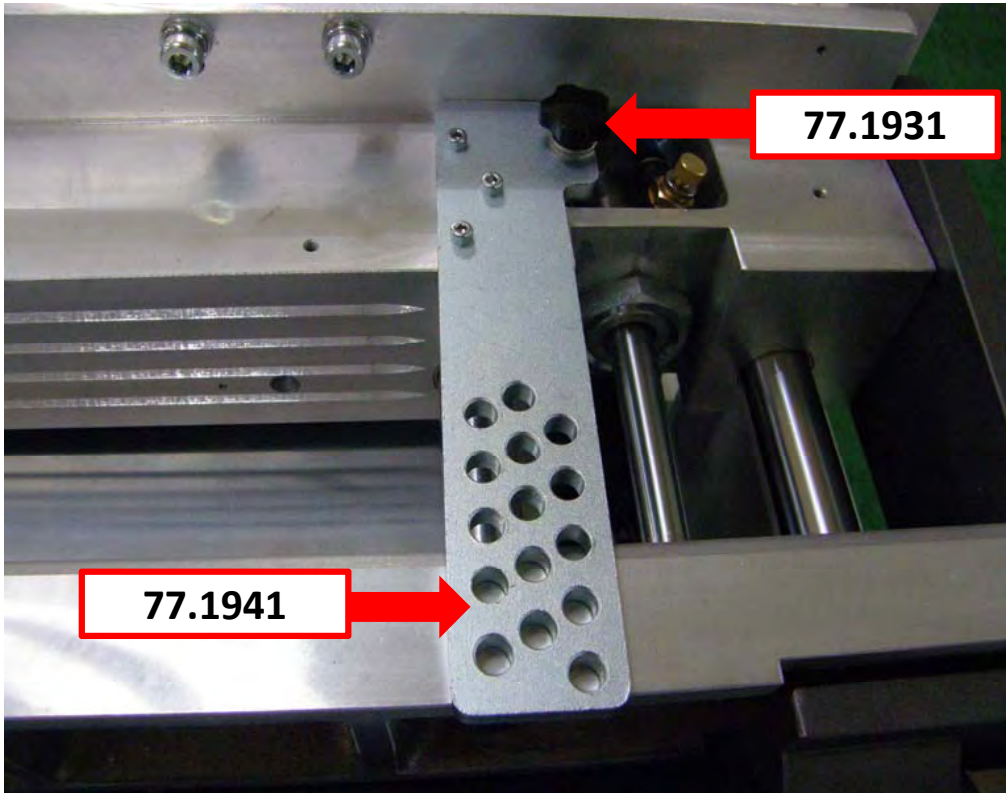

NO	Tachoplus Code	Description	Quantity
	77.1931	Clamp stop bolt	1
	77.1941	Clamp stop bar	1
	77.1960	Emergency stop switch	1

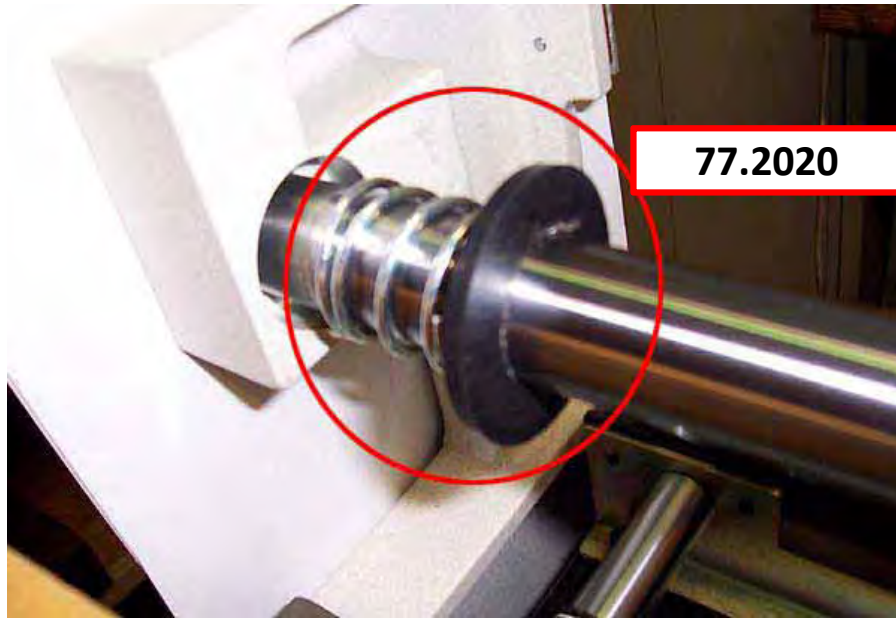
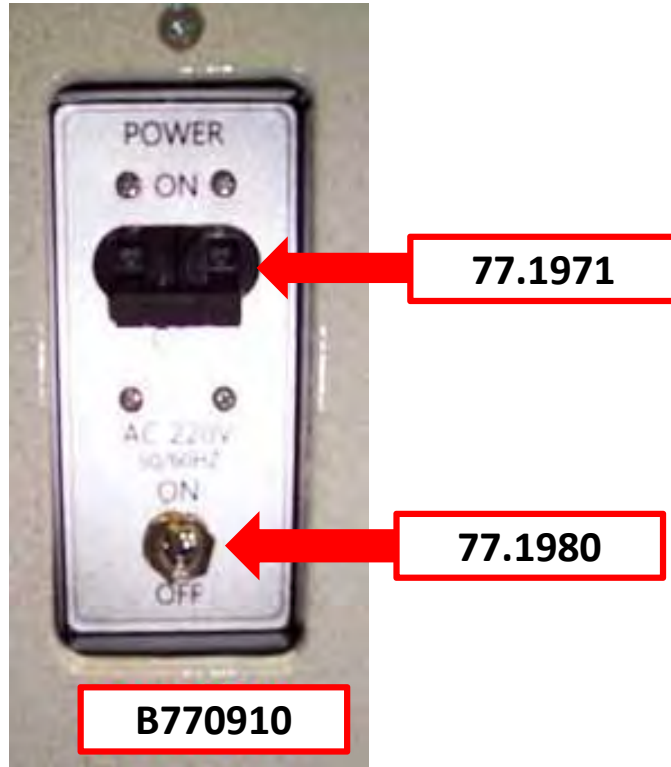

NO	Tachoplus Code	Description	Quantity
	77.1971	Main switch	1
	77.1980	Switch for slitting tool	1
	77.2020	End stop spring cpl.	1
	B770910	Main Switch tool	1

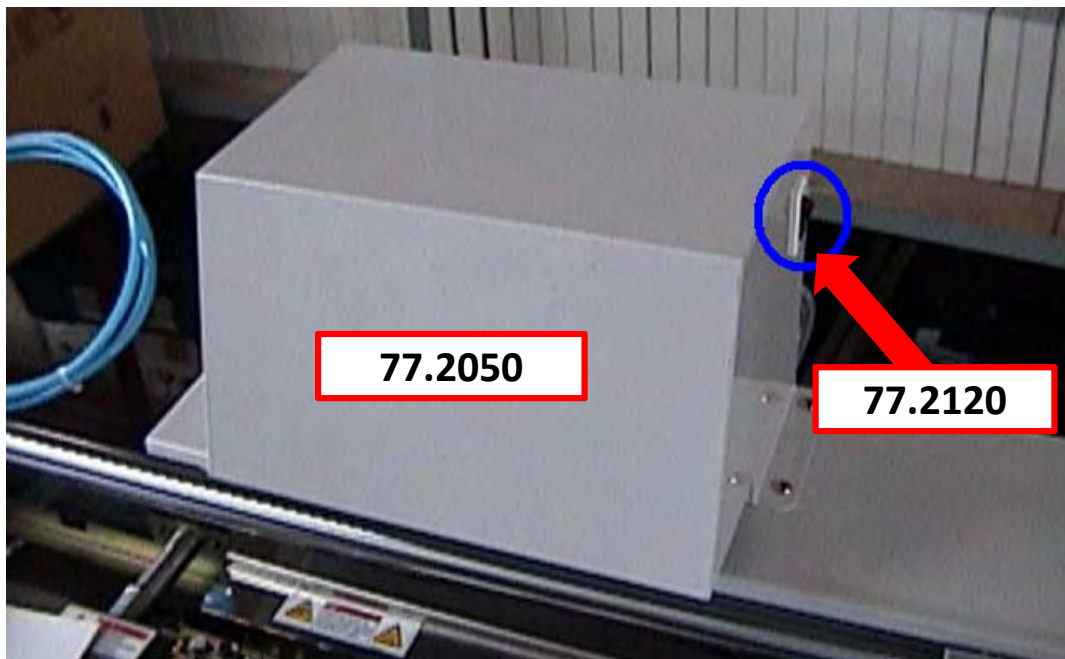
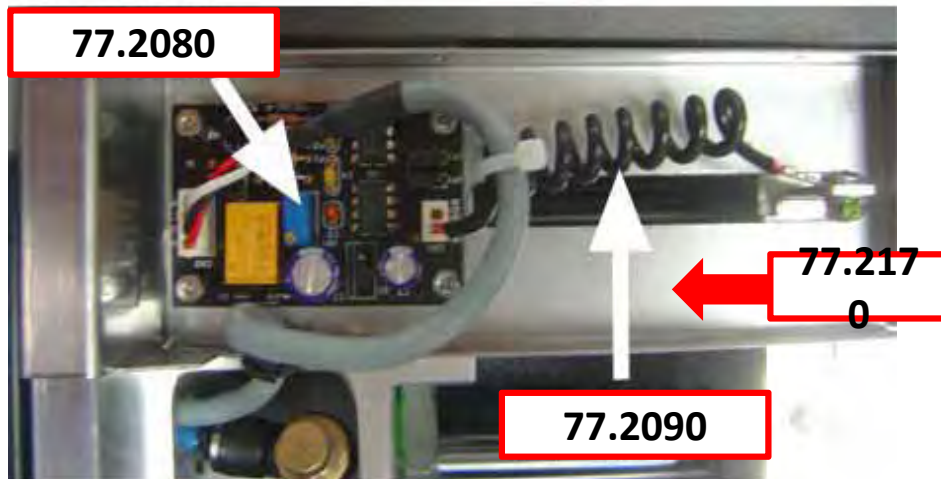
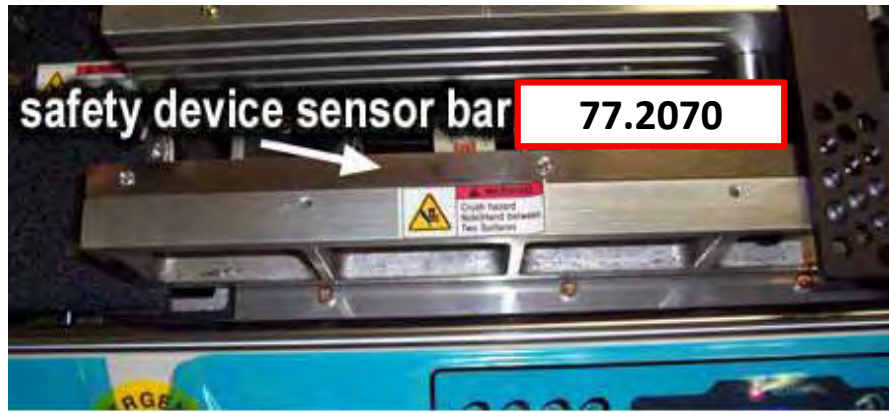

NO	Tachoplus Code	Description	Quantity
	77.2050	Exhauster	1
	77.2070	Safety device sensor bar	1
	77.2080	Safety device PCB	1
	77.2090	Connection sensor Bar to PCB	1
	77.2120	On/off-switch for exhauster	1
	77.2170	Safety hood	1



NO	Tachoplus Code	Description	Quantity
	77.1180	Left vise clamp all cpl.	1
	B771620	Glue Pot	1

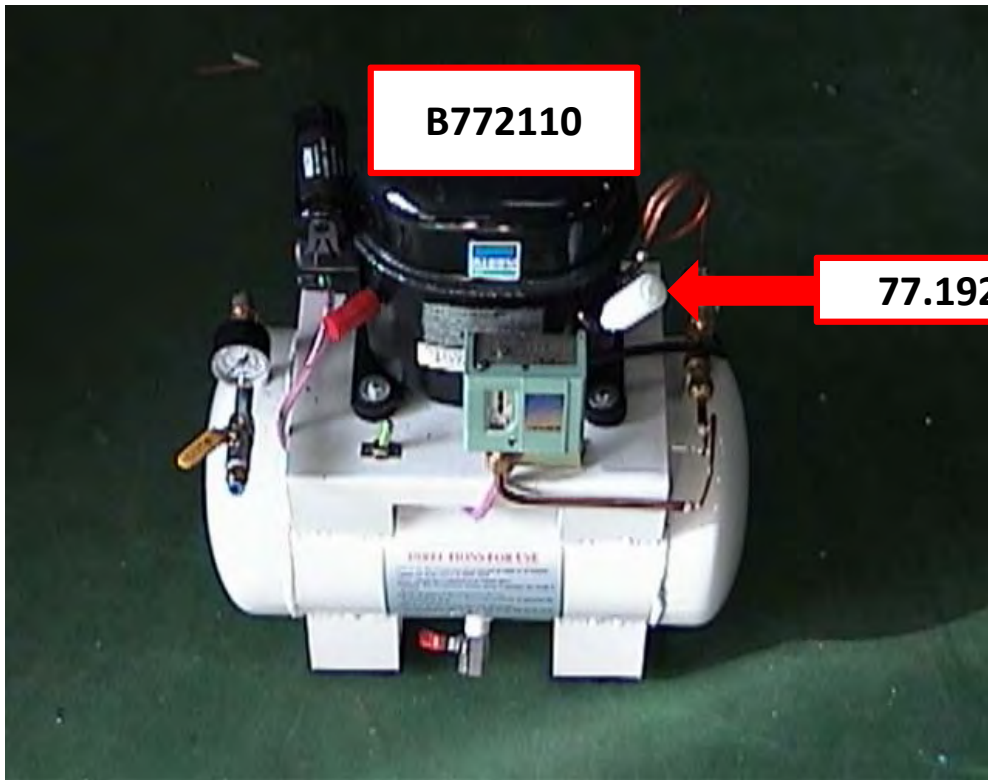

NO	Tachoplus Code	Description	Quantity
	77.1920	Air filter	
	B772110	Compressor	1

**77.7100**



**77.7110**



NO	Tachoplus Code	Description	Quantity
	77.7100	Scarping motor	1
	77.7110	Slide shaft	1

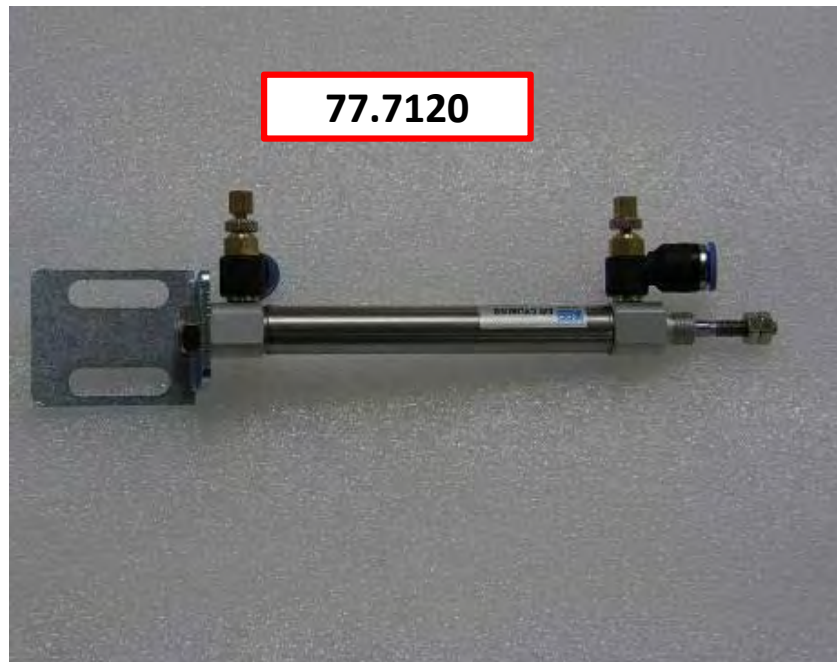

NO	Tachoplus Code	Description	Quantity
	77.7120	Scarping cover cylinder	1
	77.7130	Cover side bearing	1

**77.7140**



**77.7150**



When ordering notching pins or a roughing blade, indicate the model and serial number of your machine.

**77.7160**



NO	Tachoplus Code	Description	Quantity
	77.7140	Slit/fan housing box	1
	77.7150	Slit tool	1
	77.7160	Dusty filter	1

77.7200

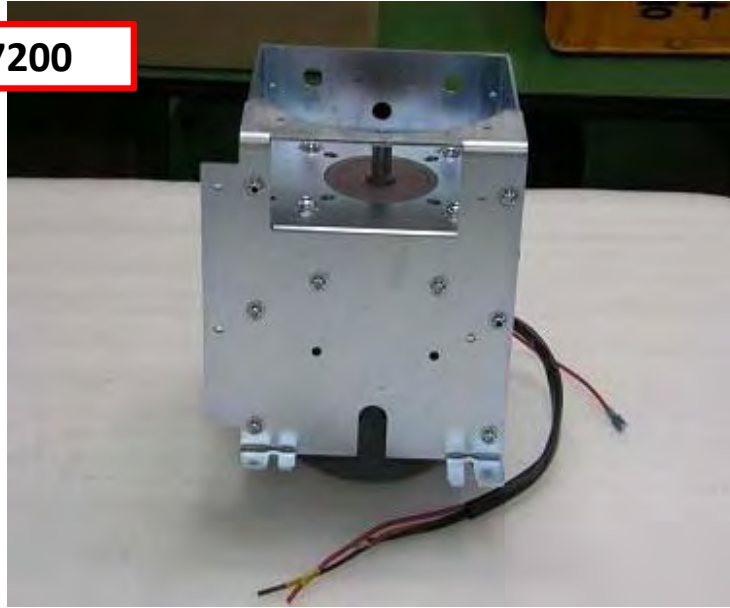

77.7210



77.7220



NO	Tachoplus Code	Description	Quantity
	77.7200	Scarping cover	1
	77.7210	Bearing fixing plate	1
	77.7220	Scarping middle cover	1

77.7230



77.7240

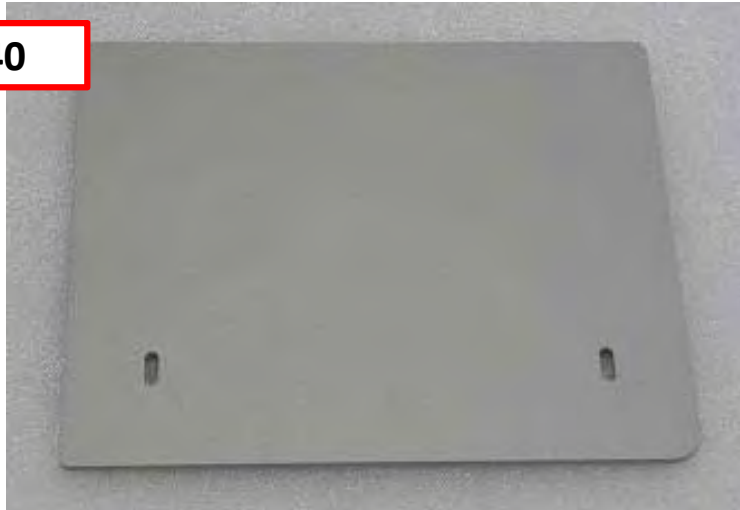

77.7250



NO	Tachoplus Code	Description	Quantity
	77.7230	Sensor bracket	1
	77.7240	Scarping back cover	1
	77.7250	Scarping front cover	1



**77.7260**



**77.7270**



**77.7280**

NO	Tachoplus Code	Description	Quantity
	77.7260	Dusty gear board	1
	77.7270	Brush fixing board	1
	77.7280	Scarping cover cylinder fixing bracket	1

**77.7290**



**77.7300**



NO	Tachoplus Code	Description	Quantity
	77.7290	Dusty vacuum box	1
	77.7300	Sucking box	1

77.7310

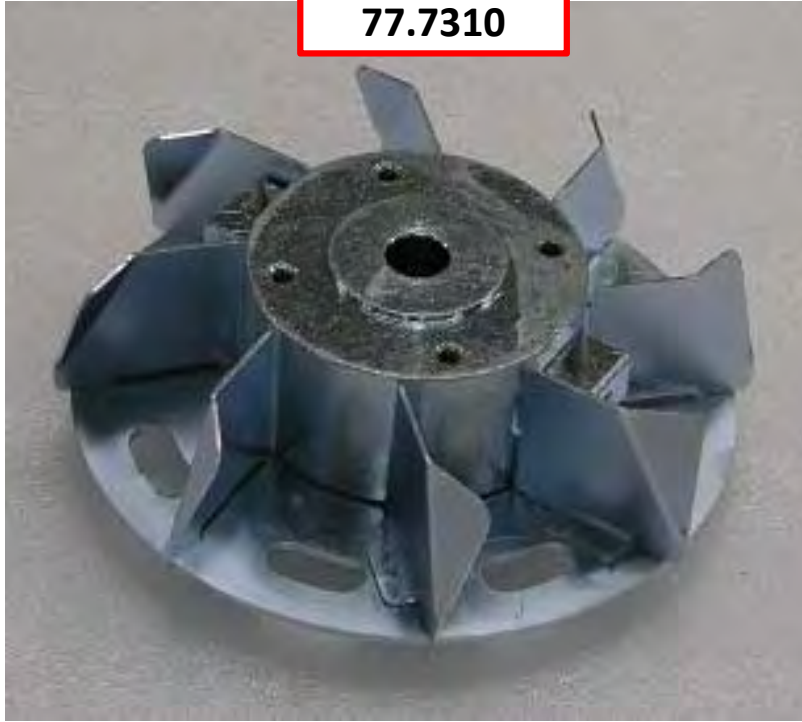

B780310



NO	Tachoplus Code	Description	Quantity
	77.7310	Scarping fan	1
	B780310	Scarping cpl.	1



NO	Tachoplus Code	Description	Quantity
	77.8100	Safety cover	1
	77.8110	Safety cover PC board	1
	B782200	Safety cover cpl.	1

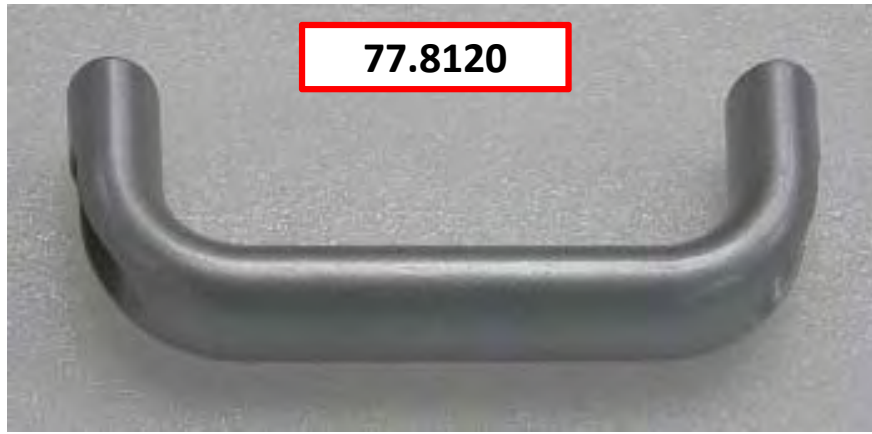

NO	Tachoplus Code	Description	Quantity
	77.8120	Safety cover handle	1
	77.8130	Cover fixing pin (right)	1
	77.8140	Cover fixing pin (left)	1
	77.8150	Safety cover sensor	1

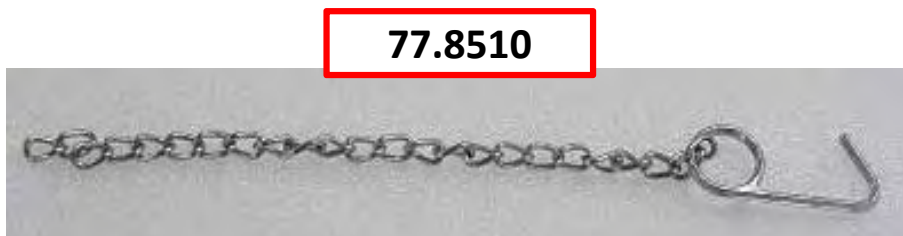

NO	Tachoplus Code	Description	Quantity
	77.8240	Main chain gear fixing board	1
	77.8250	Safety key switch	1
	77.8500	Front cover case	1
	77.8510	Front cover case fixing ring	1