

The Challenge Machinery Company provides owner's manuals on its products solely as a courtesy to its customers. See the information below before using this manual.

These manuals are for reference only. These manuals include products which are non-current, unsupported or no longer produced by The Challenge Machinery Company, and are provided solely as an accomodation to our customers. By providing these manuals, The Challenge Machinery Company makes no representation or warranty as to the products, their current condition, or their suitability or fitness for use in any particular application, which are the sole and independent responsibility of the product owner and user.

Older products may not comply with current safety procedures, guidelines or regulations, and it is the product owner's and user's responsibility to evaluate the suitability and fitness of the products in their current use and application. The Challenge Machinery Company makes no representation, warranty or recommendation regarding any modifications which may be required on non-current or unsupported products. The Challenge Machinery Company assumes no liability for any modification or alteration to any Challenge product, and any such modification or alteration to any Challenge product is not authorized by The Challenge Machinery Company. The availability of these manuals is solely for the purpose of providing reference information for the products.

This manual may not be complete in all aspects of product maintenance and repair. **All products should be used only by qualified and properly trained personnel, following proper safety procedures.** All products should be regularly inspected and maintained, and their condition, application and use should be periodically evaluated by qualified personnel. Only qualified and properly trained technicians should perform maintenance, repair and replacement procedures. Attempting these procedures without proper training may cause machine damage or operator injury!

Products may be unsupported by The Challenge Machinery Company due to age or the unavailability of parts from their original manufacturer. No parts or product support will be available to repair or maintain unsupported products. Older products may not be UL listed (if the product does not have a UL label it is not a listed product), and may not comply with applicable installation or other regulations or requirements if relocated to a new facility. Many municipalities require a product to be UL listed before an electrician will connect power to them. Often the cost of updating an older product to comply with current safety regulations is greater than the value of the product.



PAK RAK® II STOCK TRUCKS

The PAK RAK II trucks are of welded, one-piece construction with very few movable or replaceable parts. Simple cleaning and occasional oiling of the caster bearings should be enough maintenance to provide years of durable service.

SHELVES

The Pak Rak II has left and right side shelves that are not interchangeable. When ordering replacement shelves or just extra shelves, specify left or right sides.

Each shelf has (4) tabs, (3) 'L' tabs and (1) square locking tab. With the square locking tab pointing down, insert 'L' tabs into the truck body until the shelf is flush to the frame wall.

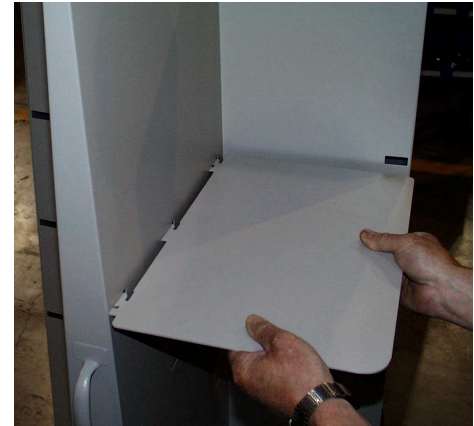

Lift the shelf slightly so the bent tab will clear the hole edges and slide the shelf into the truck body.

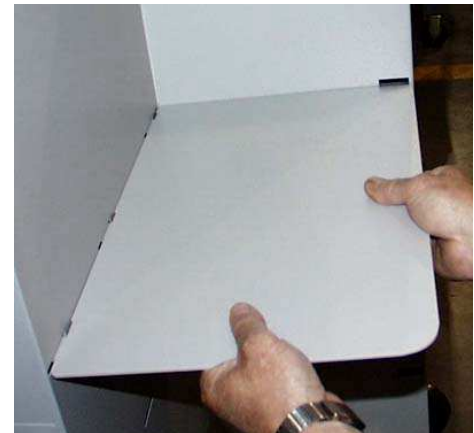

Drop the shelf down so the bent tab is seated in the frame hole.

⚠ CAUTION

DO NOT CLIMB on trucks or use as a step!

DO NOT RIDE on moving trucks!

DO NOT PUSH trucks faster than a walk! A loaded truck could easily crush someone or knock them down.

DO NOT OVERLOAD. Shelf or caster damage could result.

75lb per shelf, 400lb max. capacity.



PAK RAK II JULY 03

F.11A

WARRANTY

This equipment is guaranteed to be free from defects in workmanship or material for a period of 90 days from the date of installation, except components purchased by Challenge which carry the manufacturer's warranty.

We will repair or replace, at our option, any equipment proving defective, not caused by accident, misuse or improper maintenance, if returned to our factory, transportation prepaid.

Should you find anything wrong, contact the dealer from whom the equipment was purchased. Challenge will not be responsible for any charges incurred without its specific authorization.

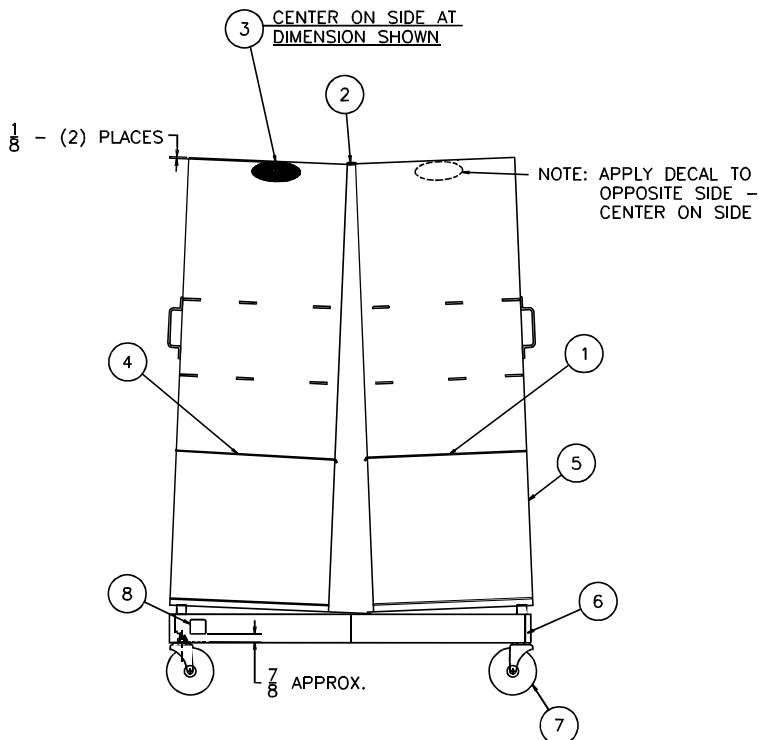

8	A-7492	IDENTIFICATION PLATE	1
7	S-1881-1	CASTER - SWIVEL, 5" DIA. (OPTIONAL IN 7/03)	4
	S-1881	CASTER - SWIVEL, 3" DIA.	
6	S-1886	PLASTIC END CAP - LEG	4
5	A-7485	FRAME WELDMENT	1
4	7490	SHELF - ADJUSTABLE - L.H.	4
3	4956-1	DECAL	2
2	S-1961	PLASTIC END CAP - TOP	1
1	7489	SHELF - ADJUSTABLE - R.H.	4
NO.	PART NO.	DESCRIPTION OF ACCESSORIES	QTY

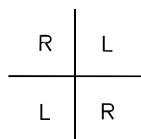

*Eight (8) shelves are supplied, slots provided for 4 optional shelves. Be sure to order correct side, left or right, for Pak RakII shelves.